

# Crater Lake Ski Patrol Handbook

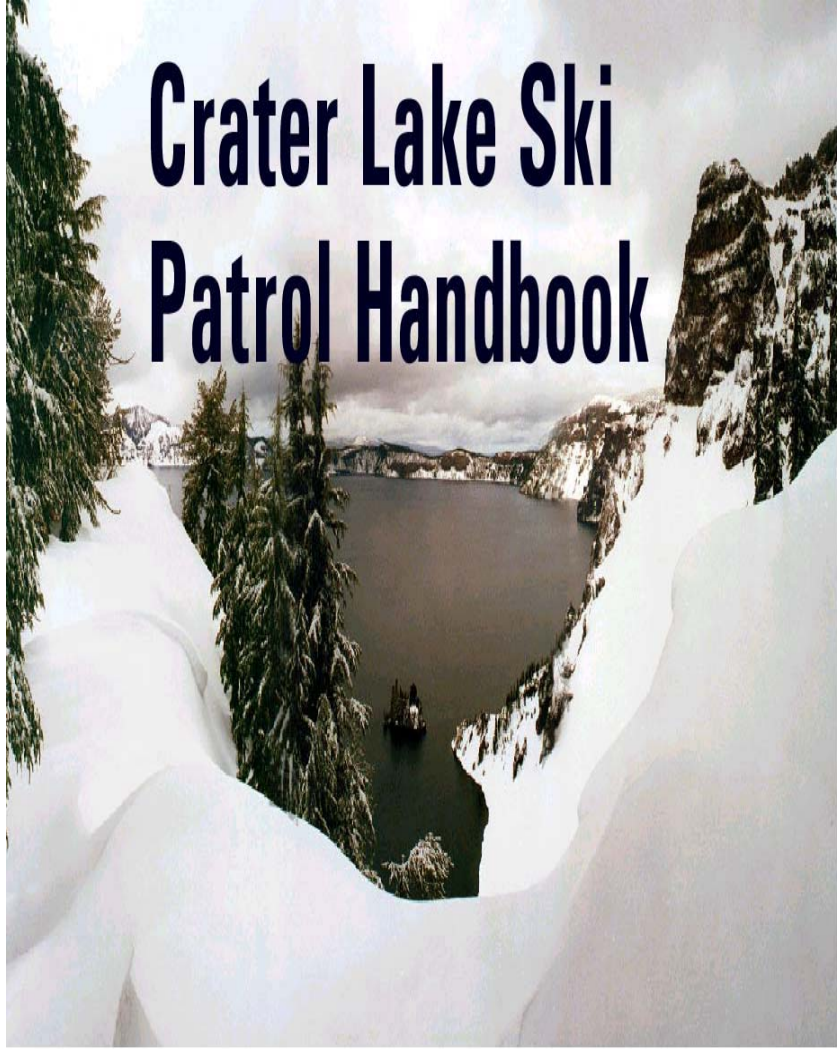

# Crater Lake

## Ski Patrol

Handbook

<sup>3rd</sup> Edition 2009

The information contained in this booklet is to be used as reference guide as to the basic standards and protocols for the Crater Lake Ski patrol. The proper use of this guide requires appropriate training in rescue techniques and emergency medicine. You are encouraged to confirm information in this booklet with other sources for current standards in Emergency medicine accordingly to your classification in Emergency medicine, i.e. Basic First Aid; First Responder; level of EMT. The authors and publisher assumes no liability with respects to accuracy, completeness or application of information contained in this booklet.

Edited by: Niel Barrett

# Table of Contents

|   |           |
|---|-----------|
| <b>1. Patrol Procedures .....</b>   | <b>1</b>  |
| Position Description, Patrol Equipment<br>List First Aid List, Radio Use, Important<br>Names And Numbers, Park Winter<br>Information & Regulations    |           |
| <b>2. Park Information .....</b>  | <b>10</b> |
| Distances & Elevations On The Rim,<br>Facts, History, Ten Frequently Asked<br>Winter Questions  |           |
| <b>3. EMS .....</b>   | <b>16</b> |
| Shock, CPR, Primary Assessment ABC's,<br>Secondary Assessment, Immobilization<br>Glasgow Coma Score, Trauma Scale<br>Call In Report, Field Run Sheets |           |
| <b>4. Cold Weather Injuries .....</b>   | <b>40</b> |
| <i>Hypothermia /Frostbite</i>   |           |

|   |           |
|---|-----------|
| <b>5. Avalanche Awareness .....</b>   | <b>44</b> |
| Critical Data Rating Score Card, Interpreting<br>The Results, Avalanche Cheat Sheet,<br>Beaufort Scale Rutschblock, Test Ratings<br>Results, Stability Test, How To Seek<br>Information Bulls Eye Approach, Digging<br>Hasty Pits, Shovel Shear Test, Interpreting<br>The Results, Ingredients For A Slab<br>Avalanche, Slope Angle, Beacons, Probing |           |
| <b>6. Shelters .....</b>  | <b>69</b> |
| Snow Caves, Shallow Snow Cave,<br>Igloo, Snow Trench  |           |
| <b>7. Map &amp; Compass .....</b>   | <b>79</b> |
| Taking A Bearing From A Map, Taking A<br>Bearing From Land, Walking A Bearing<br>Taken From Land, Back Bearings, Walking<br>Around Obstacles, Triangulation   |           |

|   |            |
|---|------------|
| <b>8. Knots &amp; Rope Systems. ....</b>  | <b>86</b>  |
| Rigged Rope Parts, Figure-Of-Eight Loop<br>Figure-Of-Eight Re-Threaded, Clove Hitch,<br>Double Fisherman's Knot, Water Knot,<br>Prusik, Safety Knots, Over Hand, The<br>Munter Hitch, Snow Anchor (s), Snow Or<br>Ice Bollard, T- Anchor, Snow Picket, Two<br>Point Anchor, Equalizing Anchor, Rope<br>Systems, Z -Rig, Lowering, Double Prusik<br>Belay (Backup), Load Releasing Hitch<br>(UMIT) |            |
| <b>9. Helicopter Safety.....</b>  | <b>110</b> |
| Approaching The Helicopter, Helicopter<br>Landing Area, Rotor Blades, Danger Areas<br>To Avoid, Good Safety Practices The<br>Landing Site   |            |

## PATROL PROCEDURES

### *POSITION DESCRIPTION*

#### **Major Duties:**

Patrollers serve as a volunteer Nordic Ski Patroller within the 182,700 acres of Crater Lake National Park. As official representative of the Crater Lake Ski Patrol and Crater Lake National Park, the patroller is expected to project a friendly and professional image. The ski patroller performs a variety of functions to include:

- Visitor information and assistance provision
- Informational, regulatory and warning sign maintenance.
- Ski trail marking.
- Safety promotion.
- Resource and safety violation recognition, prevention and correction, as appropriate
- Emergency medical services program participation.
- Search and rescue program participation.
- Weather and snowpack evaluation.
- Ski patrol and related equipment maintenance.
- Training participation and instruction.
- Report completion.

**Duties are usually performed on weekends and holidays.  
Workdays begin at 0900 and end at 1700**

## **PATROL PROCEDURES**

### *POSITION DESCRIPTION (CON'T)*

#### **Knowledge & Skills:**

Each patroller is required to acquire and maintain knowledge and skills in the following areas:

- Mountain weather.
- Snowpack analysis.
- Avalanche dynamics & prediction.
- Physical conditioning.
- Equipment maintenance.
- Emergency medical services & orienteering
- Patrol activities, & regulations.
- Winter & avalanche rescue techniques & equipment.
- Winter & avalanche search techniques.
- Skiing & snowshoeing ability.
- Snowmobile operations.
- Survival techniques & equipment.

**(Refer to ski patrol standards for additional information)**

#### **Supervisory Controls:**

The Ski Patrol Coordinator with the help of the Weekend Leader assigns duties daily. In their absence, another staff member will be designated. Most duties are routine, reoccurring and completed independently preformed. The ski patroller may be called upon to organize and supervise personnel during an emergency incident.

## PATROL PROCEDURES

### *POSITION DESCRIPTION*

**Guidelines:** Guidelines addressing orientation, policies, objectives, procedures and park information are available. The patroller should exercise initiative and judgment in identifying problems and applying guidelines.

**Complexity:** Assignments are varied, involving opportunity to apply various alternatives and methods. Standard procedures apply to most activities. The ski patroller is expected to employ initiative, ingenuity, analysis, alertness and concentration to each situation, problem and incident.

**Scope and Effect:** Work contributes to effective winter operations and to park resource preservation. Efforts influence the public's perception and enjoyment.

**Purpose or Contacts:** Contacts promote efficient operations, offer information exchange, facilitate a safe and meaningful visitor experience, and protect park resources and foster effective working relationships.

**Physical Demands:** Position requires hiking, skiing or snow shoeing for long distances at any hour of the day, at high altitudes, in inclement weather and for long hours, particularly during emergency operations. Physical strength is required to ski any snow conditions over varying terrain, haul signs and assist with injured or ill person evacuation.

## PATROL PROCEDURES

### *PATROL EQUIPMENT LIST*

1. Official Ski Patrol Red Parka, Black Pants, and Baseball Cap or Red Cap with patrol emblem.
2. Sturdy Pack.
3. Layers /gators/ gloves / extra hat.
4. Ensolite pad (Large enough to keep your torso off the snow).
5. Snow Shovel.
6. First aid kit (with the essentials to stop heavy bleeding in the field).
7. Headlamp.
8. Down or synthetic filled vest or jacket (for added insulation for night out with patient).
9. Extra hat, mittens (a replacement for the one that blows off into the rim or for patient)
10. Spare socks.
11. Extra food (power bars, dried fruit, anything that you can throw into bottom of pack for another season and forget about it.
12. Water.
13. Lightweight nylon tarp (anything that will get you or patient out of weather).

## PATROL PROCEDURES

### *PATROL EQUIPMENT LIST*

#### **Personal Items:**

1. Sunglasses, goggles, sunscreen, lip balm, ten essentials, etc.
2. Some type of fire starting kit (paraffin soaked cardboard, lighter fluid, etc).
3. Radio & spare battery (at least one between the party).
4. Avalanche transceiver.
5. Patrol Handbook. (at least one between the party).

#### **Would be nice:**

1. Small lightweight stove and small 1 cup pot to melt water.
2. Bivy sack.
3. Small lightweight sleeping bag (one or two pounder).
4. Lightweight down or synthetic filled pants.
5. More food.
6. More clothes.
7. Heat Packs.
8. Candles.
9. Rubber utility gloves (great for digging snow caves & keeping main gloves dry).

**PATROL ROCEDURES**

| <b>First Aid List</b>  |  |
|--|--|
| 1-Roll Kling - 4"<br>1-Adhesive Tape<br>2-Moleskin - 3" x 4"<br>1-Scissors<br>1-Tweezers<br>1-Needle<br>6-Large safety pins<br>1-Razor blade<br>3-Antibiotic ointment<br>10-Aspirin<br>10-Antacid tablets<br>10-Ibuprofen<br>2-Hot packs<br>1-CPR mask | 1-Small notepad<br>1-Pencil/Pen<br>2-Pair rubber gloves<br>2-Ziploc plastic bags<br>4-Anti bacterial towelettes<br>4-Gauze pads - 4" x 4"<br>Triangular Bandage<br>6-Bandaids - 1" x 3"<br>1-Bandage compress - 4"<br>1-Roller gauze - 2"<br>6-Butterfly bandages<br>1-Small tube of<br>decorate gel<br>2 - Run sheets |
| <b>Optional:</b>   |  |
| 1-EMT shears<br>1-Sam splint<br>1-Eye bandage<br>1-Thermometer   | 1-Roll 1 1/2" athletic tape<br>1-Nylon stocking (great for<br>holding on head bandages)<br>1-Stethoscope<br>1-Blood pressure cuff  |

## PATROL PROCEDURES—*RADIO USE*

**Channel 1** - Direct/no repeater/used for local traffic.

**Channel 2** - Watchman repeater/west part of park/used for most distance traffic.

**Channel 3** - Mt. Scott repeater/east side of park mostly used when skiing rim.

All the channels are on the same frequency, except 4. When your radio is set on a given channel, it may or may not receive the other channel, depending on your location. For urgent or emergency situations (e.g., rescues, motor vehicle accidents, etc.) always use **channel 2 or 3**. This allows dispatch and people responding to monitor the situation. For *routine* traffic, use *channel 1 if possible*. Channel 1 has limited range, but is useful for talking to someone else in your area without involving other park personnel. Whether initiating or receiving a call, be aware of what channel you are using.

**When initiating a call**, say the person's call sign you are calling first followed by your own call sign. Ski Patrol's call sign is "*SKI PATROL & (YOUR LAST NAME)*".

Example: "Ski Patrol - Ski Patroller Bellon"

**Dispatch** is open daily from 8:00 to 4:30. Generally, the dispatcher will be working when you arrive in the morning, but will not be there when you are done at 5:00 PM. Note; patrollers need to contact central for emergencies after 4:30 PM.

## **PATROL PROCEDURES**

### *IMPORTANT NAMES AND NUMBERS*

- ❑ Park Information Center: 541-594-3100
- ❑ Park Communication Center: 541-594 3060
- ❑ Crater Lake Lodge Company: 541-594-2255
- ❑ Central Dispatch: 911
- ❑ Park Dispatch 541-594-3060
- ❑ Admin: 541-776-7206

## **PATROL PROCEDURES**

### *PARK WINTER INFORMATION & REGULATIONS*

- Snow-Park permits are not required.
- No Skiing or Snowshoeing on plowed roads.
- No overnight lodging during the winter months.
- No roadside camping.
- All backcountry campers must register.
- Campers must ski or snowshoe to their campsite.
- The following areas are closed to camping.
  - Within one mile of any plowed road.
  - Within one mile of Boundary Springs or Sphagnum Bog.
  - Within 100 feet of any water source.
  - Within visibility of any other backcountry campers or ski trails.
- Entering the caldera is strictly forbidden.
- You are responsible for your own safety.
- Pets are not allowed on any ski routes.
- Firearms are not permitted anywhere in the park.
- No open fires during the winter season.
- Camping parties are restricted to no more than eight.
- Garbage and Sewage must be carried out.
- Backcountry users may park at the Park Headquarters, overnight area or at Rim Village overnight area.
- Snowmobileing is allowed only at the North Entrance.

**PARK INFORMATION**

*DISTANCES & ELEVATIONS ON THE RIM*

| <b>Location</b>                | <b><i>Total<br/>Mileage</i></b> | <b><i>Distance<br/>from last</i></b> | <b><i>Total<br/>Climb (ft)</i></b> |
|--------------------------------|---------------------------------|--------------------------------------|------------------------------------|
| Rim Village                    | 0.0                             | 0.0                                  | --                                 |
| Discovery Point                | 1.1                             | 1.1                                  | 50                                 |
| Lightning Springs<br>Trailhead | 2.3                             | 1.2                                  | 50                                 |
| Watchman Trailhead             | 3.8                             | 1.5                                  | 200                                |
| North Junction                 | 6.1                             | 2.3                                  | 200                                |
| Cleetwood Cove                 | 10.7                            | 4.6                                  | 450                                |
| Wineglass                      | 13.5                            | 2.8                                  | 350                                |
| Skell Head                     | 14.9                            | 1.4                                  | 400                                |
| Cloudcap                       | 17.9                            | 3.0                                  | 600                                |
| Kerr Notch                     | 21.4                            | 3.5                                  | 600                                |
| Dutton Ridge                   | 24.0                            | 2.6                                  | 650                                |
| Sun Notch                      | 25.5                            | 1.5                                  | 650                                |
| Vidae Falls                    | 27.0                            | 1.5                                  | 650                                |
| Headquarters                   | 30.0                            | 3.0                                  |                                    |

## PARK INFORMATION

### *FACTS*

- ❑ Created about 7,700 years.
- ❑ The lake averages more than 5 miles in diameter.
- ❑ Max depth 1,943.
- ❑ The deepest lake in the United States.
- ❑ Seventh deepest in the world.
- ❑ Lake temperature varies between 32°F & 66°F at the surface.
- ❑ Average snowfall: 533 inches pre year.
- ❑ Distance around the lake 33 miles.
- ❑ Wizard Island rises 764 feet above lake level.
- ❑ Scientists have identified 157 species of phytoplankton and 12 species of zooplankton in the lake.
- ❑ 90 miles of Maintained trails.
- ❑ Highest point in park: 8,929 feet at Mount Scott.
- ❑ Rim Village: 7,100 feet.
- ❑ Park Headquarters: 6,450 feet.
- ❑ Mazama Village: 6,004 feet.
- ❑ Lowest point in park: 3,977 feet at lower Red Blanket Canyon.

## **PARK INFORMATION**

### *HISTORY*

Native Americans have been aware of Crater Lake for thousands of years. The first pioneers to visit Crater Lake was a party led by John Wesley Hillman in 1853. William Gladstone Steel visited Crater Lake in 1885, and began a 17-year campaign to protect the lake as a national park. Crater Lake National Park was established on May 22, 1902. It was the seventh area to be designated a national park, the sixth still in existence today.

#### **Indian Forlorn:**

The spirit of the mountain was called Chief of the Below World (Llao). The spirit of the sky was called Chief of the "Above World" (Skell). Sometimes, Llao came up from his home inside the earth and stood on top of Mount Mazama, one of the highest mountains in the region. During one of these visits, he saw the Makalak chief's beautiful daughter and fell in love with her. He promised her eternal life if she would return with him to his lodge below the mountain. When she refused, he became angry and declared that he would destroy her people with fire. In his rage, he rushed up through the opening of his mountain and stood on top of it and began to hurl fire down upon them.

## PARK INFORMATION

### *HISTORY*

The mighty Skell took pity on the people and stood atop Mount Shasta to defend them. From their mountaintops, the two chiefs waged a furious battle. They hurled red-hot rocks as large as hills. They made the earth tremble and caused great landslides of fire. The people fled in terror to the waters of Klamath Lake.

Two holy men offered to sacrifice themselves by jumping into the pit of fire on top of Llao's mountain. Skell was moved by their bravery and drove Llao back into Mount Mazama. When the sun rose next, the great mountain was gone. It had fallen in on Llao. All that remained was a large hole. Rain fell in torrents, filling the hole with water. This is now called Crater Lake.

**Founders:** On June 12 1853, three members from the Hillman party came upon a large body of deep water that is now known as Discovery Point. Hillman exclaimed that it was the bluest water he had ever seen. Skeeters suggested naming it "*Deep Blue Lake.*"

- ❑ Steel's proposals to create a national park in 1886
- ❑ Park is established in 1902.
- ❑ The National Park Service was established on August 25, 1916.

## PARK INFORMATION

### *TEN FREQUENTLY ASKED WINTER QUESTIONS*

1. **Does the lake freeze over in the winter?** Not very often. The water volume is too large and takes a long time to give off heat. It occasionally gets thin layers of ice, but the last time it completely froze was 1949.

2. **How much snow do you get?** We average approximately 530 inches per year. The highest record for snow on the ground was 252 inches (21 feet), set on April 3, 1983.

3. **What is the quickest way to Portland?** Bend, Eugene, (Anywhere North, since the North Entrance is closed in winter)? Hwy 62 towards Klamath Falls and over to Hwy 97.

4. **Where can I view the lake (asked at Rim Village)?** Point out the snow tunnel in the Rim Village parking area when the snow bank gets to high. This is easier and safer than trying to climb the snow bank.

5. **Is there a good place to ski for beginners?** This is usually a personal opinion; nevertheless, Mazama Loop is the only "easy" ski trail in the park. Patrollers should evaluate current snow conditions and be very diligent in asking the right questions to assess the visitor's skill level, physical ability, and proper gears for the outdoors in answering this question.

**6. Where can I rent skis or snow shoes?**

The concession use to rent them at the cafeteria, but in order to save money on their staff, they are no longer providing this service. However, the park does offer ranger led snowshoe walks where snowshoes and the talk are provided free of charge.

**7. Where is the closest gas?** Thirty-five miles, either Hwy 97 heading to Klamath Falls, or Prospect, heading towards Medford.

**8. Is there any place to spend the night in the park?**

No. All lodging is closed for the winter. The closest hotels are approximately 25 miles away in Fort Klamath. Union Creek (approx 25 miles) also has lodging, except they will sometimes close during slow winter weeks.

**10. When does the snowmelt and the roads open?**

This depends on the amount of snowfall the park receives during the course of the winter. The North road is usually open by late June/early July and the Rim Road is usually open sometime in early July.

**11. When is the best time to ski around the lake and how far is it?** It is approximately 33 miles around.

The best time to ski around the lake for most (but not all) people is early spring when the temperatures are warmer and days longer.

## EMS

### **SHOCK**

#### *Signs and Symptoms*

- 1). Restlessness and anxiety.
- 2). A weak and rapid pulse ("thready" or difficult to feel).
- 3). Cold and wet, clammy skin.
- 4). Profuse sweating.
- 5). Paleness.
- 6). Shallow, labored, and rapid respirations.
- 7). Thirst may become intense.
- 8). Nausea or vomiting.
- 9). Gradual and steadily falling blood pressure (late sign).

#### ***Treatment:***

- 1). Secure and maintain an open airway.
  - 2). Control all obvious external bleeding.
  - 3). Elevate the lower extremities about 12 inches.
  - 4). Prevent heat loss, insulate under and over patient.
  - 5). Splint fractures.
  - 6). Avoid rough and excessive handling.
  - 7). Accurately record patients vitals and blood pressure.
  - 8). Do not give patient anything to eat or drink.
- In general, keep an injured patient supine. Remember, that some patients in shock after a severe heart attack or with lung disease cannot breathe as well when supine, or when sitting up or in a semi sitting position. With such patient, use the most comfortable position.

## EMS

### *CPR*

#### *Infant Up To 1 Year*

1. Make sure the scene is safe for you to help.
2. Make sure you have universal precautions: gloves, pocket mask, etc.
3. Determine if they are conscious by tapping and shouting, "Are you OK."
4. If no response, have someone summon advanced medical personal. (911)
5. If alone, give two minutes of care before calling 911
6. If parents are around GET consent.
7. Position the patient on their back.
8. Open the airway with a *Head-Tilt Chin-Lift* or use the *Jaw-Thrust* maneuver.
9. LOOK-LISTEN-&-FEEL for breaths. CHECK BREATHING FOR no more than 10 SECONDS.
10. If they are not breathing, VENTILATE TWICE-CHEEK PUFFS. ( make seal over mouth and nose) ( if chest doesn't raise, reposition head and try again)
11. Check for a pulse by palpating (feeling) the brachial (arm) artery. CHECK THE PULSE for no more than 10 SECONDS.
12. If there is no pulse BEGIN CHEST COMPRESSIONS at a rate of 30 COMPRESSIONS to 2 BREATHESES.
13. CONTINUE cycles of 30 compressions to 2 breaths until: The scene becomes unsafe. You find signs of life. An AED is ready to use. You are too exhausted to continue. Another trained responder arrives.

## EMS

### *CPR*

#### *Child 1–8 Years*

1. Make sure the scene is safe for you to help.
2. Make sure you have universal precautions: gloves, pocket mask, etc.
3. Determine if they are conscious by tapping and shouting, "Are you OK?"
4. If no response have someone summon advanced medical personal. (911)
5. Position the patient on their back.
6. Open The Airway With A Head-Tilt Chin-Lift Or Jaw-Thrust Maneuver.
7. Look-Listen-&-Feel for Breaths.  
Check Breathing no more than 10 Seconds.
8. If They Are Not Breathing, Ventilate Twice.
9. Check For A Pulse By Palpating (Feeling) The Carotid Artery. Check The Pulse for no more than 10 Seconds.
10. If There Is No Pulse begin Chest Compressions at a Rate of 30 Compressions to 2 Breaths. (makes seal over mouth and pinch nose)
11. CONTINUE cycles of 30 compressions to 2 breaths until: The scene becomes unsafe. You find signs of life. An AED is ready to use. You are too exhausted to continue. Another trained responder arrives.

## EMS

### *CPR*

#### *Adult 8-Years And Above*

1. Make sure the scene is safe for you to help.
2. Make sure you have universal precautions:  
gloves, pocket mask, etc.
3. Make sure you know how many patients you have.
4. Determine if they are conscious by tapping and shouting, "Are you OK?"
5. If no response have someone summon advanced medical personal. (911)
6. Position the patient on their back.
7. Open the airway with a head-tilt chin-lift or jaw-thrust maneuver.
8. LOOK-LISTEN-&-FEEL for breaths. CHECK BREATHING FOR no more than 10 SECONDS.
9. If they are not breathing, VENTILATE TWICE.
10. If chest doesn't rise reposition head and try giving 2 breaths again
11. Check for a pulse by palpating (feeling) the carotid artery. CHECK THE PULSE FOR no more than 10 SECONDS.
12. If there is no pulse BEGIN CHEST COMPRESSIONS at a rate of 30 COMPRESSIONS to 2 BREATHS
13. CONTINUE cycles of 30 compressions to 2 breaths until: The scene becomes unsafe. You find signs of life. An AED is ready to use. You are too exhausted to continue. Another trained responder arrives.

## EMS

### *PRIMARY ASSESSMENT ABC's*

#### **Level of Consciousness:**

- Hey! Are you okay?"

#### **Airway:**

- Is the airway open?
- Will it stay open?
- Does anything endanger it?

Keep the spine stable, open the airway, suction, and insert airway adjunct as necessary. If trauma is suspected, use a jaw thrust and manually stabilize the head/neck.

#### **Breathing:**

- Are respirations adequate?
- Is there chest trauma?

Ventilate and/or start oxygen as necessary. Quickly check the chest, treat, and treat chest trauma.

- Can the patient take a deep breath?
- Is there trouble breathing?

Quickly listen for equal breath sounds.

#### **Circulation:**

- Check and assess pulse.
- Is there life threatening hemorrhage?

Begin CPR and control hemorrhage as necessary. Check for capillary refill and have crew get baseline vitals.

## EMS

### *PRIMARY ASSESSMENT*

#### **Disability:**

- What is the level of consciousness using the AVPU scale?
- Is there evidence of major CNS injury?
- Apply a rigid extrication collar if it does not compromise the airway.

#### **Expose:**

- Do not remove clothing if possible. Keep patient warm because of environment.

### *PATIENT STATUS*

#### **Arrested or Unstable - "Load and Go"**

If patient is being ventilated, or a major Airway, Breathing, or Circulation problem is discovered during primary assessment, the patient *is* unstable. Transport/ Immobilize to a spineboard, provide supportive care, and do a secondary assessment while enroute to the hospital.

#### **Potentially Unstable or Stable**

A secondary assessment should be started to further define the scope of the patient's problems. If the secondary assessment does not reveal any life threatening problems, routine packaging of the patient may proceed.

## EMS

### *SECONDARY ASSESSMENT VITAL SIGNS*

#### **Pulse:**

- RATE: Check radial pulse; if found, BP is usually 80mm/Hg. If pulse is regular, count for 15 seconds and multiply times 4. If irregular, count for 60 seconds.
- QUALITY: Is pulse regular or irregular? Strong or weak? Pattern?

#### **Respirations:**

- RATE: Watch chest/abdomen & count for full 60 sec.
- QUALITY: Normal or labored? Shallow or deep? Pattern?

#### **Blood Pressure: (BP)**

- Auscultate BP. If scene is noisy, palpate to obtain systolic.

#### **Skin:**

- LOOK: Is it normal? Pale? Cyanotic? Flushed?
- FEEL: Is it Warm? Cold? Wet? Dry?

### *PATIENT HISTORY*

#### **Chief Complaint:**

- Why did you call? What's the problem?

#### **History of the current Problem:**

- What happened? If trauma, what was the mechanism of injury? Were you unconscious? To investigate pain, consider a mnemonic such as OPQRST.

#### **Previous History:**

- Any allergies? Taking any medications? Under a physician's care? Use SAMPLE.

**PHYSICAL EXAMINATION**

**Head:**

- Inspect and palpate the scalp/skull, ears, and facial bones. Inspect the eyes, pupils, mouth, and nose.

**Neck:**

- Palpate the cervical spine. Inspect and palpate the soft tissue. Inspect trachea and neck veins.

**Chest:**

- Inspect and palpate the shoulders/devices, and rib cage. Can patient take a deep breath? Auscultate for equal air entry.

**Abdomen:**

- Inspect and palpate all 4 quadrants, and the flanks.

**Posterior Thorax:**

- Palpate the back. Inspect if appropriate.

**Pelvis/Buttocks:**

- Palpate and apply pressure over iliac wings and pubic symphysis.

**Extremities:**

- Inspect and palpate all 4 extremities. Check for sensation and movement, and assess circulation in all extremities.

**CFR**

IF you find yourself without a BP Cuff: Remember CFR.

- C -- Carotid pulse = Systolic BP of at least 60mm/Hg.
- F -- Femoral pulse = Systolic BP of at least 70mm/Hg.
- R -- Radial pulse = Systolic BP of at least 80mm/Hg.

## EMS

### *IMMOBIZATION*

#### *LONG BONE INJURY*

1. Take body substance isolation precautions (rubber gloves).
2. Apply manual stabilization of the injury.
3. Assess motor, sensory and distal circulation in the injured extremity.
4. Measure the splint.
5. Apply the splint.
6. Immobilize the joint above the injury site.
7. Immobilize the joint below the injury site.
8. Secure the entire injured extremity.
9. Immobilize the hand or foot in the position of function.
10. Reassess motor, sensory and distal circulation in the injured extremity.

## EMS

### *IMMOBIZATION*

#### *OPEN CLOSED FRACTURE*

1. Take body substance isolation precautions.
2. Expose the injured extremity.
3. Explain procedure to the patient.
4. Instruct the assistant to immobilize the extremity. **without** applying traction.
5. Check for pulse distal to the injury.
6. Assess sensation and movement prior to splinting the injury.
7. If wound is open, remove gross contamination with normal saline or sterile water.
8. Apply and secure a sterile dressing to the wound.
9. Select and size appropriate splint.
10. Pad and splint.
11. Gently lift the injured extremity while supporting under fracture site. Instruct the assistant in placing the splint. **(Does not apply traction.)**
12. Secure the splint without covering the wound site.
13. Immobilize joints above and below the fracture site.
14. Reassess circulation distal to the injury.
15. Reassess sensation and movement distal to the injury.

## EMS

### *JOINT INJURY*

1. Take body substance isolation precautions.
2. Direct manual stabilization of the injury.
3. Assess motor, sensory and distal circulation.
4. Select proper splint for the job and size splint accordingly to injury.
5. Immobilize the site of the injury.
6. Immobilize bone above injured joint.
7. Immobilize bone below injured joint.
8. Reassess motor, sensory and distal circulation.

## EMS

### *SPINAL IMMOBILIZATION*

1. Take body substance isolation precautions.
2. Direct assistant to place/maintain head in the neutral inline position and maintain manual immobilization of the head.
3. Assess motor, sensory and distal circulation in each extremity.
4. Apply appropriate size extrication collar.
5. Position the immobilization device appropriately.
6. Logroll the patient onto the device without compromising the integrity of the spine.
7. Apply padding to voids between the torso and the board as necessary.
8. Immobilize the patient's torso to the device.
9. Evaluate the pads under the patient's head as necessary.
10. Immobilize the patient's head to the device.
11. Secure the patient's legs to the device.
12. Secure the patient's arms to the device as necessary.
13. Reassess motor, sensory and distal circulation in each extremity.

EMS

GLASGOW COMA SCORE

**CHILD & ADULT**

**Eye Opening**

|               |         |
|---------------|---------|
| Spontaneously | 4       |
| To command    | 3       |
| To pain       | 2       |
| No response   | 1 _____ |

**Best Verbal Response**

|                        |         |
|------------------------|---------|
| Oriented               | 5       |
| Confused               | 4       |
| Inappropriate          | 3       |
| Words Incomprehensible | 2       |
| No response            | 1 _____ |

**Best Motor Response**

|                     |         |
|---------------------|---------|
| Obeys commands      | 6       |
| Localizes pain      | 5       |
| Withdraws from pain | 4       |
| Flexion (to pain)   | 3       |
| Extension (to pain) | 2       |
| No response         | 1 _____ |

**Total Score** \_\_\_\_\_ = \_\_\_\_\_

|                          |           |         |
|--------------------------|-----------|---------|
| <i>Converted Glasgow</i> | 13 - 15 = | 4       |
| <i>Coma</i>              | 9 - 12 =  | 3       |
| <i>Score (Trauma)</i>    | 6 - 8 =   | 2       |
|                          | 4 - 5 =   | 1       |
|                          | 3 =       | 0 _____ |

EMS

*TRAUMA SCALE*

|                         |         |        |
|-------------------------|---------|--------|
| <i>Respiratory Rate</i> | 10 - 29 | 4      |
|                         | ≥ 30    | 3      |
|                         | 6 - 9   | 2      |
|                         | 1 - 5   | 1      |
|                         | NONE    | 0_____ |

|                    |         |        |
|--------------------|---------|--------|
| <i>Systolic BP</i> | ≥ 90    | 4      |
|                    | 76 - 89 | 3      |
|                    | 50 - 75 | 2      |
|                    | 1 - 49  | 1      |
|                    | NONE    | 0_____ |

|                                  |   |   |
|----------------------------------|---|---|
| <i>Add Glasgow Coma</i>          |   | 4 |
| <i>Covert Trauma</i>             |   | 3 |
| <i>Score</i> _____               | = | 2 |
| <i>(Bottom of Previous page)</i> |   |   |
|                                  |   | 1 |
|                                  |   | 0 |

*Total Trauma Scale Score*..... = \_\_\_\_\_

## EMS

CALL IN

### ***Initial Report:***

1. What is your exact Location?
2. What Happened?
3. Who and what is involved?
4. Are there hazards?
5. What do you need?
6. Who are you?
7. How do we contact you?

### **EMS Radio Report:**

1. Location?
2. Chief Complaint and what type?
  - a. How many patients?
3. Approximate age?
4. Conscious: Yes: No...or alert?
  - a. Level of Distress (pain) (1-10)
  - b. Is there chest pain?
  - c. Bleeding.
5. Past Medical History
6. Medications.
7. Allergies.
8. Emergency Care Given.
9. ETA.

**EMS**

*FIELD RUN SHEET*

*Patient* \_\_\_\_\_

*Age* \_\_\_\_\_ *Sex* \_\_\_\_\_ *Date* \_\_\_\_\_

*Chief Complaint* \_\_\_\_\_

*Vitals*

| <i>Time</i> | <i>Pulse</i> | <i>Resp.</i> | <i>BP</i> | <i>LOC</i> | <i>Pupils</i> | <i>Skin</i> |
|-------------|--------------|--------------|-----------|------------|---------------|-------------|
|             |              |              |           |            |               |             |
|             |              |              |           |            |               |             |
|             |              |              |           |            |               |             |

Level of Consciousness LOC X 4

(person, ,place, time, day)

Mental Status (AVPV)

**A = Alert**.....Yes No  
**V = Responds to Verbal Stimuli**.....Yes No  
**P = Responses to Pain**.....Yes No  
**U =Unresponsive**.....Yes No

EMS

*FIELD RUN SHEET - PATIENT HISTORY  
(SAMPLE)*

S = Sign's & Symptoms \_\_\_\_\_  
\_\_\_\_\_

A = Allergies \_\_\_\_\_

M = Medications (or drugs) \_\_\_\_\_

Past Medical History \_\_\_\_\_  
\_\_\_\_\_

L = Last Meal or Drink \_\_\_\_\_

E = Events prior to incident \_\_\_\_\_  
\_\_\_\_\_

*PAIN ASSESSMENT (OPQRST)*

O= onset (when started) \_\_\_\_\_

P = Provoked (what started it) \_\_\_\_\_

Q = Quality (sharp, dull, etc.) \_\_\_\_\_

R = Radiates (to where) \_\_\_\_\_

S = Severity (scale of 1 -10) \_\_\_\_\_

T = Time (how it changes over time) \_\_\_\_\_

**EMS**

*FIELD RUN SHEET*

*Patient* \_\_\_\_\_

*Age* \_\_\_\_\_ *Sex* \_\_\_\_\_ *Date* \_\_\_\_\_

*Chief Complaint* \_\_\_\_\_

\_\_\_\_\_

*Vitals*

| <i>Time</i> | <i>Pulse</i> | <i>Resp.</i> | <i>BP</i> | <i>LOC</i> | <i>Pupils</i> | <i>Skin</i> |
|-------------|--------------|--------------|-----------|------------|---------------|-------------|
|             |              |              |           |            |               |             |
|             |              |              |           |            |               |             |
|             |              |              |           |            |               |             |

Level of Consciousness LOC X 4

(person, ,place, time, day)

Mental Status (AVPV)

**A = Alert**..... Yes No  
**V = Responds to Verbal Stimuli**..... Yes No  
**P = Responses to Pain**..... Yes No  
**U = Unresponsive**..... Yes No

EMS

*FIELD RUN SHEET - PATIENT HISTORY  
(SAMPLE)*

S = Sign's & Symptoms \_\_\_\_\_  
\_\_\_\_\_

A = Allergies \_\_\_\_\_

M = Medications (or drugs) \_\_\_\_\_

Past Medical History \_\_\_\_\_  
\_\_\_\_\_

L = Last Meal or Drink \_\_\_\_\_

E = Events prior to incident \_\_\_\_\_  
\_\_\_\_\_

*PAIN ASSESSMENT (OPQRST)*

O= onset (when started) \_\_\_\_\_

P = Provoked (what started it) \_\_\_\_\_

Q = Quality (sharp, dull, etc.) \_\_\_\_\_

R = Radiates (to where) \_\_\_\_\_

S = Severity (scale of 1 -10) \_\_\_\_\_

T = Time (how it changes over time) \_\_\_\_\_

**EMS**

*FIELD RUN SHEET*

*Patient* \_\_\_\_\_

*Age* \_\_\_\_\_ *Sex* \_\_\_\_\_ *Date* \_\_\_\_\_

*Chief Complaint* \_\_\_\_\_

\_\_\_\_\_

*Vitals*

| <i>Time</i> | <i>Pulse</i> | <i>Resp.</i> | <i>BP</i> | <i>LOC</i> | <i>Pupils</i> | <i>Skin</i> |
|-------------|--------------|--------------|-----------|------------|---------------|-------------|
|             |              |              |           |            |               |             |
|             |              |              |           |            |               |             |
|             |              |              |           |            |               |             |

Level of Consciousness LOC X 4

(person, ,place, time, day)

Mental Status (AVPV)

**A = Alert**.....Yes No  
**V = Responds to Verbal Stimuli**.....Yes No  
**P = Responses to Pain**.....Yes No  
**U = Unresponsive**.....Yes No

EMS

*FIELD RUN SHEET - PATIENT HISTORY  
(SAMPLE)*

S = Sign's & Symptoms \_\_\_\_\_  
\_\_\_\_\_

A = Allergies \_\_\_\_\_

M = Medications (or drugs) \_\_\_\_\_

Past Medical History \_\_\_\_\_  
\_\_\_\_\_

L = Last Meal or Drink \_\_\_\_\_

E = Events prior to incident \_\_\_\_\_  
\_\_\_\_\_

*PAIN ASSESSMENT (OPQRST)*

O= onset (when started) \_\_\_\_\_

P = Provoked (what started it) \_\_\_\_\_

Q = Quality (sharp, dull, etc.) \_\_\_\_\_

R = Radiates (to where) \_\_\_\_\_

S = Severity (scale of 1 -10) \_\_\_\_\_

T = Time (how it changes over time) \_\_\_\_\_

EMS

FIELD RUN SHEET

Patient \_\_\_\_\_

Age \_\_\_\_\_ Sex \_\_\_\_\_ Date \_\_\_\_\_

Chief Complaint \_\_\_\_\_

Vitals

| Time | Pulse | Resp. | BP | LOC | Pupils | Skin |
|------|-------|-------|----|-----|--------|------|
|      |       |       |    |     |        |      |
|      |       |       |    |     |        |      |
|      |       |       |    |     |        |      |

Level of Consciousness LOC X 4

(person, ,place, time, day)

Mental Status (AVPV)

**A = Alert**..... Yes No  
**V = Responds to Verbal Stimuli**..... Yes No  
**P = Responses to Pain**..... Yes No  
**U = Unresponsive**..... Yes No

EMS

*FIELD RUN SHEET - PATIENT HISTORY  
(SAMPLE)*

S = Sign's & Symptoms \_\_\_\_\_  
\_\_\_\_\_

A = Allergies \_\_\_\_\_

M = Medications (or drugs) \_\_\_\_\_

Past Medical History \_\_\_\_\_  
\_\_\_\_\_

L = Last Meal or Drink \_\_\_\_\_

E = Events prior to incident \_\_\_\_\_  
\_\_\_\_\_

*PAIN ASSESSMENT (OPQRST)*

O= onset (when started) \_\_\_\_\_

P = Provoked (what started it) \_\_\_\_\_

Q = Quality (sharp, dull, etc.) \_\_\_\_\_

R = Radiates (to where) \_\_\_\_\_

S = Severity (scale of 1 -10) \_\_\_\_\_

T = Time (how it changes over time) \_\_\_\_\_

## COLD WEATHER INJURIES

### *HYPOTHERMIA*

Hypothermia varies with age, physical condition, trauma, and disease in body, drugs, and activity. A PERSON IS NOT DEAD UNTIL THEY ARE WARM AND DEAD!

#### **The levels of Hypothermia:**

- Mild (90 to 95 F)
- Moderate (82 to 90 F)
- Severe (below 82 F)

#### **Signs and Symptoms:**

- Shivering.
- Trembling on one side of the body.
- Shivering does not occur if temperature is < 90 F.
- LOC –disorientation, confusion, aggressiveness.
- Amnesia.
- Poor judgment.
- Semi-rigid skin, bloated face.
- Apathy, Stupor, unconsciousness, coma.

## COLD WEATHER INJURIES

### *HYPOTHERMIA (CONTINUED)*

#### **Treatment:**

- ❑ Prevent further heat loss.
- ❑ Rewarm as quickly as possible:
  - *Passive: for mild cases.*
  - *Active: is dangerous in the field.*
  - *Internal: in hospital setting only.*
- ❑ *Treat complications.*
- ❑ *Transport ASAP; administer oxygen, ABC's.*
- ❑ *In severe cases, do not Rewarm, transport and be prepared for cardiac arrest.*

**Note:** handle all severe hypothermia cases with extreme care. Any sudden movements or rough handling can send the patient into cardiac arrest.

## COLD WEATHER INJURIES

### *FROSTBITE*

#### ***Three Stages of Frostbite:***

1. *Incipient* (frostbite): Tips of appendages (minor)
2. *Superficial*: Involves skin-tissue below the skin.
3. *Deep*: Tissue beneath the skin is frozen.

#### ***Four degrees of Frostbite:***

***First:*** Skin white and plaque-like (after rewarming skin is red, hot, and dry)

***Second:*** Skin becomes white with blisters containing clear fluid (After rewarming, blisters become straw colored)

***Third:*** Skin is discolored and fails to blanch with pressure. Small deep blisters are dark (after rewarming, tissue dies, blisters are bloody)

***Fourth:*** Full thickness freeze, including muscle – bone. Skin white to deep purple with no feeling, swelling blistering. (After rewarming major tissue dies)

## COLD WEATHER INJURIES

### *FROSTBITE (CONTINUED)*

#### **Treatment:**

- a. Insulate patient from cold.
- b. Don't thaw if any danger of refreezing.
- c. Protect injured area from friction & pressure.
- d. When appropriate thaw tissues rapidly and aggressively.
- e. Immerse in water 100 to 110 F (never use dry heat)
- f. Give analgesics for pain if indicated (*need consent from physician*)
- g. Elevate affected part.
- h. Prevent infection and further trauma to affected area.
- i. Do not rub area.
- j. Transport ASAP with O2.

**AVALANCHE AWARENESS**

*CRITICAL DATA*

*RATING*

***PARAMETERS KEY INFORMATION G Y R***

***TERRAIN:*** Is the terrain capable of producing an avalanche?

- Slope Angle:  
(Steep enough to slide?)
- Slope Aspect: (Leeward,  
Shadowed or extremely sunny?)
- Slope Configuration:  
(Anchoring? shape?)

***OVAL ALL TERRAIN RATING***

***SNOWPACK:*** *Could the snow fail?*

- Slab Configuration: (slab  
depth and distribution?)
- Bonding Ability:  
(Weak layer(s)? tender spots?)
- Sensitivity:  
(How much force to fail?  
shear tests? clues?)
- Hasty Pit:  
(Dig for clues?)

***OVAL ALL SNOWPACK RATING***

**AVALANCHE AWARENESS**

*CRITICAL DATA*

*RATING*

***PARAMETERS - KEY INFORMATION G Y R***

***WEATHER:*** Is the weather contributing to instability?

- |  |                          |                          |                          |
|--|--------------------------|--------------------------|--------------------------|
| <input type="checkbox"/> Precipitation:<br>(Type, amount, intensity?<br>added weight?) | <input type="checkbox"/> | <input type="checkbox"/> | <input type="checkbox"/> |
| <input type="checkbox"/> Wind:<br>(Snow transport?<br>amount and rate of deposition?)  | <input type="checkbox"/> | <input type="checkbox"/> | <input type="checkbox"/> |
| <input type="checkbox"/> Temperature:<br>(Storm trends? effects on snowpack?)          | <input type="checkbox"/> | <input type="checkbox"/> | <input type="checkbox"/> |

***OVAL ALL WEATHER RATING***

***HUMAN:*** What are your alternatives and their possible consequences?

- |  |                          |                          |                          |
|--|--------------------------|--------------------------|--------------------------|
| <input type="checkbox"/> Attitude:<br>(Toward life? Risk? Goals?<br>Assumptions?)        | <input type="checkbox"/> | <input type="checkbox"/> | <input type="checkbox"/> |
| <input type="checkbox"/> Technical Skill Level:<br>(Traveling? evaluating aval. hazard?) | <input type="checkbox"/> | <input type="checkbox"/> | <input type="checkbox"/> |
| <input type="checkbox"/> Strength-Equipment:<br>(Strength, prepared for the worst)       | <input type="checkbox"/> | <input type="checkbox"/> | <input type="checkbox"/> |

***OVAL ALL HUMAN RATING***

DECISION – ACTION

OVERALL RATING (GO or NO-GO)      **GO**      **NO GO**

|                          |                          |
|--------------------------|--------------------------|
| <input type="checkbox"/> | <input type="checkbox"/> |
|--------------------------|--------------------------|

**AVALANCHE AWARENESS**

*INTERPRETING THE DATA*

| <u>Data</u>   | Terrain  | Snowpack | Weather | Human | <u>Decision:</u><br>* Go or<br>* No Go |   |
|---------------|--|----------|---------|-------|--|---|
| HAZARD RATING | R  | R        | R       | G     | R                                      |   |
|               | G  | G        | G       | G     | G                                      |   |
|               | R  | G        | G       | G     | G                                      |   |
|               | G  | R        | R       | G     | G                                      |   |
|               | R  | R        | G       | G     | R                                      |   |
|               | R  | G        | R       | G     | G                                      | Y |
|               | R  | Y        | Y       | G     | Y                                      | R |
|               | <p><b><u>KEY</u></b></p> <p>R = RED LIGHT<br/>G = GREEN LIGHT<br/>Y = YELLOW LIGHT</p> |          |         |       |  |   |



## **AVALANCHE AWARENESS**

### ***AVALANCHE CHEAT SHEET***

Here is a text version of an avalanche cheat sheet to use when traveling in the backcountry. This can go on a (two- sided) index card and carried in your pocket or pack. This is no substitute for training, but works as a reminder. The Beaufort-wind-scale helps to determine wind loading.

**WEATHER:** Top 10 Avalanche watch-out situations.

1. Heavy dense snowfall or rain.
2. New snowfall greater than 12 inches, any density.
3. New snowfall rate greater than 1 inch per hour.
4. Wind loading greater than 15 mph.
5. Long/clear/cold spells followed by significant snowfall or wind loading.
6. Storms that begin cold and end warm.
7. Rapid temperature during the day.
8. Prolonged period of above-freezing temps.
9. Intense sun especially near cliff bands.
10. Any combination of above.

## AVALANCHE AWARENESS

### *BEAUFORT SCALE* (Measured in MPH)

- ❑ 1 mph - Smoke rises vertically.
- ❑ 1-3 mph - Smoke shows direction.
- ❑ 4 -7 - Wind felt on face, leaves rustle.
- ❑ 8-12 - Leaves & twigs in constant motion.
- ❑ 13-18 - Moves small branches.
- ❑ 19-24 - Large branches sway.
- ❑ 25-31 - Large branches in continuous motion.
- ❑ 32-38 - Whole trees in motion, inconvenient walking/skiing.
- ❑ 39-46 - Breaks twigs & small branches, difficult to walk/ski.
- ❑ 47-54 - Litters ground with broken branches.
- ❑ 55-63 - Trees uprooted, considerable damage.
- ❑ 64-75 - Widespread structural damage.
- ❑ 75+ mph - Severe and extensive damage.

## AVALANCHE AWARENESS

*RUTSCHBLOCK TEST RATINGS* (Block = 6'x5'x5' deep)

Test Safe/Short Slope Greater than 30 degrees with same aspect and elevation of suspect slope. Slope must be facing same direction as suspect slope.

1. Block fails as you isolate it or walk above it.
2. Block fails when you carefully step on it.
3. Block fails when you make a sudden sinking or deep-knee bend.
4. Block fails when you jump vigorously with skis.
5. Block fails when you jump vigorously with skis a second time.
6. Block fails when you jump repeatedly with or without skis.
7. Block does not fail.

| <b>SCORE</b>    | <b>RATING</b>                                      | <b>COMMENTS</b>  |
|-----------------|--|--|
| <i>1,2,or 3</i> | <i>High to Extreme Hazard<br/><u>RED LIGHT</u></i> | <i>Avoid all Slopes Above 25</i>                                       |
| <i>4 or 5</i>   | <i>Moderate<br/><u>YELLOW LIGHT</u></i>            | <i>Avalanches Possible on Slopes Greater Than 35 Degrees</i>           |
| <i>6 or 7</i>   | <i>Low<br/><u>GREEN LIGHT</u></i>                  | <i>Avalanches Unlikely Except in Isolated Pockets or Steep Gullies</i> |

# AVALANCHE AWARENESS

## RUTSCHBLOCK

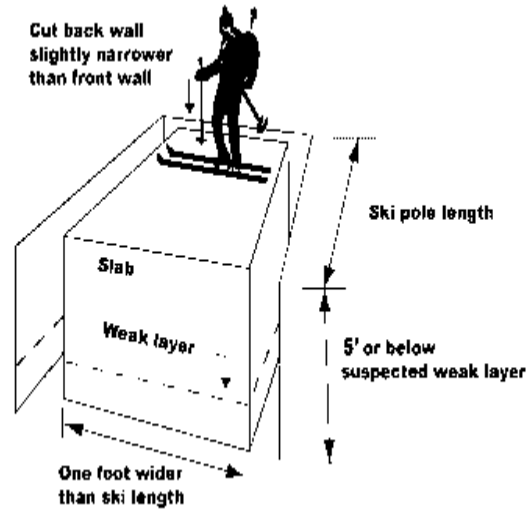

*Refer to (page 48) for the **Rutschblock Test Rating Scores.***  
*Refer to (page 50) for instruction on how to do **Rutschblock testing steps.***

## AVALANCHE AWARENESS

### *RUTSCHBLOCK*

#### *Rutschblock Test Steps*

1. Locate a site that is representative of the slope in question. (*Same steepness & orientation*)
2. The slope should be at least 30 degrees and in a safe area.
3. Dig down to just below the weakest layer. (*Generally 3 to 5 feet deep*)
4. Dig the length slightly longer than your ski.
5. At the ends cut back about half a ski length.
6. Cut or saw down the back on the uphill side.
7. Load the block with a skier. Carefully approach the block from above and stand with skis parallel to the uphill side.
8. Step onto the block one ski at a time and flex at the knees. (*As in weighting the skis in a turn*).
9. If failure does not fall then the skier jumps on the block. (Being prepared to slide off with the block).
10. Failure should produce a smooth, clean shear parallel to the slope. After the block fails, examine the failure plane to assess the type and size of the snow grains.

## AVALANCHE AWARENESS

### *HOW TO SEEK INFORMATION*

**Is it safe or unsafe?** This is the question you need to answer before traveling on or near slopes capable of producing avalanches. The essential problem you are faced with is one of uncertainty; you just do not know whether the slope is safe or not.

The key to eliminating or reducing uncertainty lies in gathering meaningful information upon which you can base your evaluation. Some of the most unambiguous information available is in the form of clues provided by Nature. These clues reflect on-going physical processes, which affect the stability of the snowpack. By choosing information that provides a high degree of certainty and by seeking a variety of clues that reinforce the message, you can quickly make an evaluation based upon meaningful information. This process is called the Bull's Eye Approach. It means getting to the heart of the problem without getting bogged down in the irrelevant information. On the following page 52 is a chart showing how this works.

## AVALANCHE AWARENESS

### *BULLS EYE APPROACH*

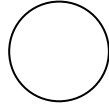

Within this circle exists all of the information available to you whether meaningless or useful. Examples:

*The sky is clear and the temperature is 12 degrees F (11 degree C).*

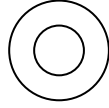

Within this area exists all of the data that is particularly **relevant** to your problem.

Example: *There is one foot of new, powder snow. Some of this snow is being transported by strong north winds.*

Within this circle exists information that is highly **meaningful**. Example: *South-facing slopes are avalanching due to heavy wind loading. The presence of avalanche activity leaves little uncertainty in your mind about the potential hazard on south-facing slopes that have not been released.*



***IN SEEKING INFORMATION  
GO FOR THE BULL'S EYE***

## AVALANCHE AWARENESS

### *DIGGING HASTY PITS*

1. Choose a spot with the same conditions similar to those you are evaluating.
  - a. (Same elevation, slope, angle, aspect & snow conditions)
2. Dig a pit 4-5 feet deep and wide enough to work in (approx. 4 feet). As you shovel, pay attention to the changes in the snow layers.
3. Smooth off the back-wall with your snow shovel.



**Resistance Test:** Insert a thin object (credit card or knife) into the top of the pit wall & run it down the wall. Feeling the resistance of the layers and noting the boundaries of hard & soft layers.

### **Stratigraphy Test:**

1. Using a hat or mitten, lightly brush the pit wall from the top down, with horizontal strokes.
2. The layers of the snowpack will be revealed in a series of ridges and valleys. The raised or ridged surfaces indicate the harder, stronger layers that may be possible slabs or sliding surfaces. The valleyed surfaces reveal softer, weaker layers.

*Shovel Shear Test*

1. Isolate a column of snow equal to the width of your snow shovel on the pit wall.
2. Cut the back of the column with snow saw or skis.
3. Slowly insert your shovel or ski (tip up & binding facing up slope) at the back of the column & pull gently forward.
4. Slab layers will usually break off along a clean plane.
5. The ease with which they break is an indicator of how poorly the layers are bonded.

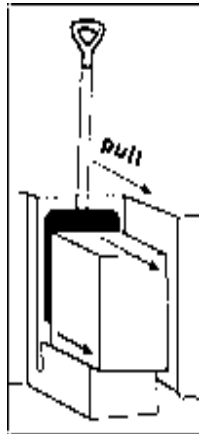

The ease with which a column shears is rated as very easy, easy, moderate, hard, very hard. Generally, "very easy" & "easy" shears are considered indicators of unstable snow while "moderate", "hard", & "very hard" shears reflect varying degrees of unstable snowpack.

Best Method for Performing Shear test is to use a shovel (see figure) however, using a ski's trail will work as well.

## AVALANCHE AWARENESS

### HASTY PIT

| <b><i>INTERPRETING RESULTS<br/>OF THE HASTY PIT</i></b>   | <b>What Do These<br/>Scores Mean?</b><br>"1, 2, & 3"   |
|---|--|
| <p>Loading Steps That Cause the Block to Move:</p> <ol style="list-style-type: none"><li>1. The block fails when you are digging or sawing.</li><li>2. The block fails when skier is approaching the block or gently stepping onto the upper third of block.</li><li>3. The block fails when skier down weights, or flexes at knees with feet in place.</li></ol> | <p><b><i>POOR<br/>STABILITY<br/>*Red Light*</i></b></p> <p><i>Similar slopes<br/>should be<br/>considered very<br/>unstable.</i></p> |

**AVALANCHE AWARENESS HASTY PIT**

*What Do These Scores Mean?*

|  |   |
|--|---|
| 4. The block fails when skier does a single vigorous jump in the same spot.    | <i>POOR STABILITY</i><br><b>*Red Light*</b><br>Similar slopes should be considered very unstable.   |
| 5. The block fails when skier does a second vigorous jump in the same spot.    | <i>FAIR STABILITY</i><br><b>*Yellow Light*</b><br>Similar slopes should be considered "unstable" or "suspicious". Proper route selection and safety measures are essential. |
| 6. Fails after repeated hard jumps or after jumping onto bottom half of block. | <i>GOOD STABILITY</i><br><b>*Green Light*</b><br>Low risk of triggering slabs on similar slopes.  |

The safest bet is to use snowpit and shear test results to tell you that the snowpack in a given area is unstable, but not to tell you that it is stable, unless these results are well corroborated by other data. A good rule of thumb is that if you are uncertain about stability, choose your terrain accordingly.

**Remember stability tests are just ONE piece of the puzzle.**

**AVALANCHE AWARENESS**  
*INGREDIENTS FOR A SLAB AVALANCHE*

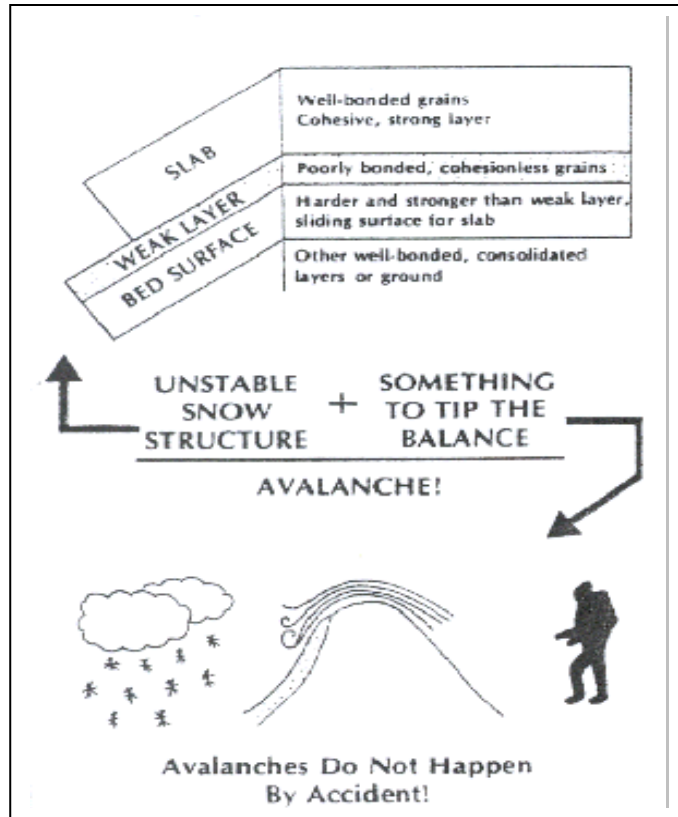

## AVALANCHE AWARENESS

### *SLOPE ANGLE*

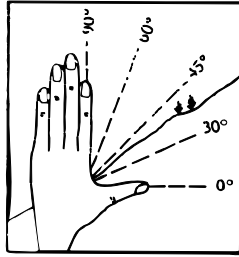

Holding your index finger and thumb at a right angle, line up the slope in the apex of your hand. If the slope divides the apex in half, the slope is approximately 45 degrees. The slope is roughly 30 degrees or less if the slope divides the apex in the lower third and 60 degrees or more if it divides it in the upper third.

This method works best if you pre-mark your poles into 10 equal sections. In the diagram, when the pole held horizontally to the snow surface meets the vertical pole in the midsection, the angle is 26.5 degrees. When the two handles are touching, the angle is 45 degrees. Thus, a 10:10 (or 1:1) ratio between the markings on the poles is a 45-degree angle; a 6:10 ratio is a 30-degree angle; and a 5:10 ratio is a 26.5-degree angle.

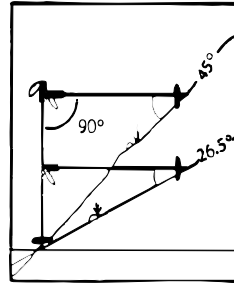

## AVALANCHE AWARENESS    *SLOPE ANGLE CON.*

Slope angle is a *critical* variable determining avalanche potential. Slab avalanches are possible only within a certain range of slope angles, generally between 25 and 60 degrees. The word *generally* is highlighted because this range is variable and depends on a number of factors including climate. Above 60 degrees, the stresses on the snowpack are so great that the snow tends to continually sluff off. Below 25 degrees, the stresses on the snowpack are usually not great enough to cause the snow to slide although in warm, very wet snowpack avalanches have occurred on slopes of less than 20 degrees. The majority of slab avalanches start on slopes & in gullies with angles between 30 and 45 degrees.

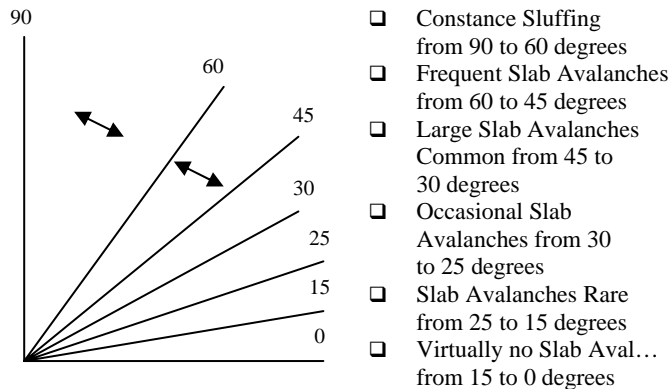

Remember, as the slope angle increases,  
so does the stress on the snowpack

## AVALANCHE AWARENESS

### USING YOUR TRACKER BEACON

#### *Single Burial Search*

**Objective: Locate signal**

- If no "last seen point," search entire debris pile.
- Rotate Tracker horizontally/vertically.
- Max 20m between searchers or switchbacks.

**Objective: Locate smallest distance reading (Strongest signal)**

- Use Tracker close to snow surface.
- Ignore fluctuations in distance and direction.
- Begin probing at lowest distance.
- Use Tracker in hole during deep excavations.

**Objective: Move quickly to 10m, slowly to 3m**

- Keep flashing light within center 3 windows.
- Move quickly in direction Tracker is pointing.
- Make sure distance is decreasing.
- Slow down at 10m

PRIMARYSEARCH >40m

PINPOINT SEARCH < 3m

SECONDARY SEARCH 3-40m

## AVALANCHE AWARENESS

### *USING THE TRACKER BEACON*

#### *Multiple Burial Search*

If the Tracker displays more than one signal, follow the one with the lowest distance reading. Once you are within about meters, the Tracker will isolate that signal. Turn off the first beacon once it is found. If you can't turn it off, and don't see a signal, stay in SE mode. Take three steps back and circle victim. Repeat up to three times (nine steps). If no signal is return to the point at which you abandoned the primary search and continue the search from there.

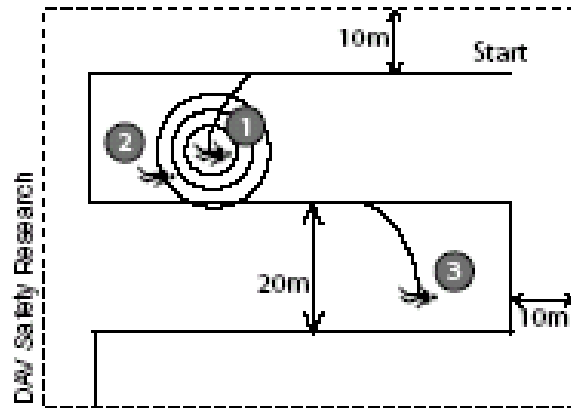

## AVALANCHE AWARENESS

### *USING THE TRACKER BEACON*

#### *Signal Primary Search*

The signal search refers to the process of establishing a search pattern and looking for a signal. The search pattern will be defined by the victim's last seen area, the size of the slide, and the number of searchers. Refer to Figures B and C, below, to establish a primary search pattern. If the slide is less than 20 meters wide, the primary search path will be directly down the center. If the victim's last seen area is well defined, the primary search will follow a direct path down the fall line from this point.

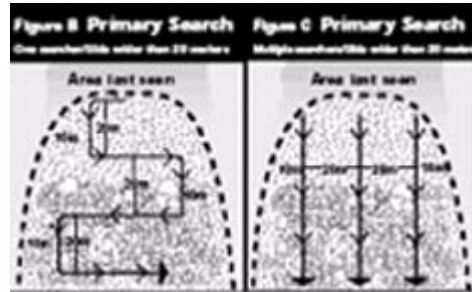

## AVALANCHE AWARENESS

### *USING THE TRACKER BEACON*

Rotate the Tracker slowly in your hand, but move rapidly down the search path. Do not abandon your search path until you have captured a strong, steady signal. Ignore irregular signals, which can sometimes be caused by electrical interference

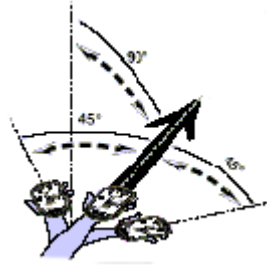

Prior to the primary search, be sure that all transceivers are turned to search mode. Rotate the Tracker slowly back and forth on a horizontal and vertical plane (Figure D) while moving in the direction as defined by your primary search pattern. While searching, be aware of other physical clues, such as equipment or extremities protruding from the snow surface. When no signal is detected, "SE" will flash in the distance indicator. Once a signal is detected consistently, mark this spot and begin the fine search.

## AVALANCHE AWARENESS

### *USING THE TRACKER BEACON*

#### *Secondary/Fine Search*

The secondary search (also referred to as the fine search) is the portion of the search from where you have detected a steady signal to where you are close to the victim. Once the signal is consistently detected, rotate the Tracker slowly on a horizontal plane until the center direction light (7) is blinking. The Tracker is now pointed in the direction of the strongest signal, or your direction of travel (Figure E). The four lights (7) on either side of center tell you which way to rotate the Tracker to engage the center light. The distance indicator (2) tells you, in approximate meters, how far you must travel (1 meter = 1.1 yards or 3.3 feet). If the number on the distance indicator is increasing, you are on the same axis as the victim's signal, but moving in the opposite direction. Turn 180 degrees, engage the center search light again, and continue your search in the direction the Tracker is pointing. This is preferable to walking backwards, in which case the Tracker will often flash "SE" rather than show a direction and distance. If you are stationary, but the distance is significantly changing, you are probably detecting the signal of another rescuer. Make sure all rescuers are in search mode before continuing.

## AVALANCHE AWARENESS

### **Using The Tracker Beacon**

*The Tracker is very sensitive. Slight (see figure E) movement in any direction will actuate a different search light. Rotate it very slowly so as not to "skip" over the center search light window. In special (SP) mode, signals are only displayed if they fall within the center three windows*

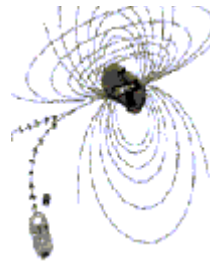

**Figure E**

You may find that, while following the directional lights, your route follows an arc. This is because the Tracker DTS performs the fine search using the "flux (or induction) line" method (see Figure F). It follows the shape of the electromagnetic signal, or flux line pattern, coming from the transmitting beacon's antenna. The distance displayed is the distance to be traveled along that flux line, not the straight-line distance from you to the victim.

**Figure F**

*The Tracker follows the Shape of the electromagnetic flux lines coming from the transmitting beacon's antenna. your path during the fine search will be either straight (point A) or curved (point B), depending on the orientation of your beacon when the signal is first captured. Note: the Tracker's transmitting antenna (10) is oriented at a 45-degree angle to the long axis of its case, as shown.*



# AVALANCHE AWARENESS

## USING THE TRACKER BEACON

### *Flux Line Search*

Dual antenna, digital technology makes the Tracker the only transceiver in the world that can follow the true “flux” or “induction” line search method. Five directional lights point which direction to travel. A distance display indicates how far. The searcher never stops to reorient, change direction, or adjust volume. This makes it easier to learn and faster to use—especially for inexperienced beacon users.

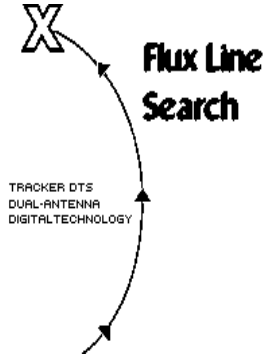

### *Grid Search (single antenna)*

Traditional “gridding” or “bracketing” is the oldest, most widely taught beacon search method. The searcher must travel far enough along one axis to detect significant audible “fade points,” then backtrack to the midpoint, stop, adjust volume, travel perpendicular to the previous axis, and repeat. This requires extensive backtracking.

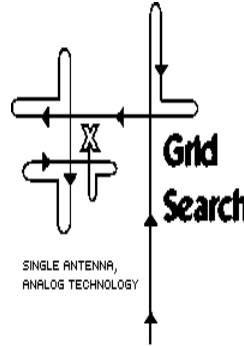

# AVALANCHE AWARENESS

## USING SINGLE ANTENNA BEACON'S

### *Beacons*

#### **Tangent Search**

*(This Method Is Used only On Single Antenna Beacons)*

Using the "tangent" search method, the searcher travels in five- meter line segments tangent to the flux line. Every five meters, the user must stop and reorient the beacon to determine the signals fade points. In the last three meters, the searcher must pinpoint using the grid method. A tangent search can be faster than a grid search, but still requires stopping to reorient, adjust volume, and pinpoint.



## AVALANCHE AWARENESS

### *PROBING*

*Probe first at likely areas, near pieces of the victims equipment, at the marked points of disappearance, and around trees and rocks. If there is no success: set up a probe line.*

#### **Course Probe:**

1. Line up searchers elbow to elbow in line.
2. Insert probes once between feet.
3. Take one step forward, uphill along the most likely search route.
4. Probe again, then another step.
  - *Every Searcher Must Be In Unison At The Spoken Command Of The Leader.*
5. If a searcher hits something, have another searcher dig at that spot. (*Separate from probe line*)
6. After one run up the slope, the probe line moves to one side of the original course and starts probing, again probing uphill.

#### **Fine Probe:**

- A fine probe is used only after a course probe has failed and there is no hope of any live rescue. A fine probe is basically the same as a course probe except you would probe between your feet and at the tip of each foot and move uphill only half a step at a time.

## SHELTERS

### SNOW CAVE

*A snow shelter heated with a candle will help you survive the night in relative comfort and help keep your patient alive.*

#### **Snow Caves:**

1. Find a safe spot. You want to avoid any potential avalanche slopes and any windward slopes where blowing snow could seal you in the cave. Try to find some type of small slope or bank with snow at least six feet deep. A slope is much easier to dig a cave in than the flats.
2. Try to stay dry. Take turns and work slowly but efficiently to avoid excess sweating. Dig the entryway - tunnel into the slope about three feet and then begin angling and excavating upward to clear a living space.
3. You need to leave the cave ceiling at least one foot deep to keep it from collapsing.
4. Put the cave floor above the top of the entry tunnel to trap warm air inside.
5. Make the ceiling and walls smooth so melting snow will run down the walls and not drip on occupants.
6. Punch a ventilation hole in ceiling, and cover the entrance if possible with a tarp or snow blocks.

## SHELTERS

### *SNOW CAVE (continued)*

- Depending on how many occupants the snow cave will house, you should allow 1 to 1 ½ hour per person to dig the cave. If the snowpack is firm and icy, allow two hours per person.

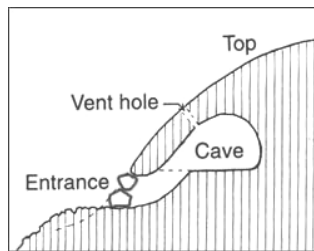
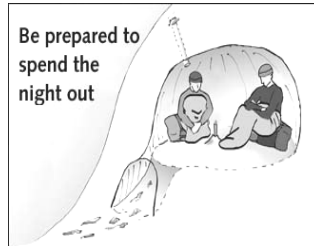

## SHELTERS

### *SHALLOW SNOW CAVE*

There is also a way to build an emergency snow cave with at least 6 inches of snow. This takes about 3 hours for a 2-3-person cave.

1. Find a *flat* location and draw a circle in the snow with a diameter of 10-12 feet.
2. Shovel snow into a big pile within the circle, packing it down until its center is about 6-7 feet high.
3. Place (dead) twigs about 12-18 inches in length into the mound of snow at several locations.
4. Let the pile of snow sit for an hour or so, then tunnel into the pile. Excavate enough snow to make a small room. Then continue carving out the inside until you come to the twigs placed earlier.
5. Place a ventilation hole in the top.



## SHELTERS

### *IGLOO*

Igloos are equal in protection to snow caves, but the traditional dome-shaped igloo built of snow blocks that spiral upward to the top requires proper snow consistency or preparation, plus a builder with a good bit of expertise. Wet, packed snow provides blocks that stick together and stay in place, but makes them heavy and difficult to handle. Wind-packed snow is the easiest to work with.

1. If the snow is soft, stomp it down and let it consolidate for around 30 minutes before starting to saw blocks with a snow saw or shovel. The area you stomp down will be used as your *quarry* where you will harvest your snow blocks.
2. Each snow block should measure about 2 ½ feet by 1 1/2 feet by 1/2 foot.
3. Bevel the bottom of each block so the wall will tilt inward at the proper angle.
4. Hold each block in place as it is installed while the cracks are chinked with snow.
5. The igloo entrance should be below floor level so warm air is trapped inside.

## SHELTERS

### *IGLOO*

1. Building an arch that you can walk through requires a solid base of at least three rows of blocks built up in pyramid style on each side. Prepare all of the top arch blocks before lifting them into place. To do this, lay the blocks flat on the ground at the doorway. Carefully cut each block to fit just as they would when in the air.

2. Now, have a friend hold the angled blocks on both sides as you insert the "keystone" block from the top. You can then let go of the blocks and the arch will stand. You can cut between the blocks to get a tight fit.

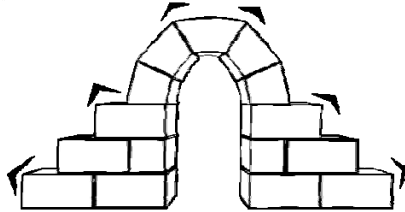

## SHELTERS

### *IGLOO*

#### **Block Cutting**

1. Good snow blocks are essential for snow construction. Find firm snow that will hold your weight when standing on it. Try to avoid snow with dirt or stones or ice in it. Begin by cutting two parallel lines about one snow saw length apart. Be sure to cut deep enough by penetrating the snow right up to the handle. The blocks that you remove will be beginning of you your quarry.
2. Remove the first small block and discard it (the triangle shaped one). Now you can cut the back and bottom of the block. Note: You must cut all sides to the block to free it from the snow bank. Good building blocks should be at least one snow saw wide one and a half snow saws long and three quarters of a snow saw deep.
3. With good snow blocks that are not too thin, you can build nearly anything. A good challenge is make the block as you can safely carry.

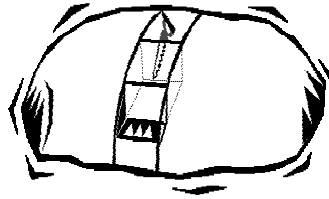

*(BLOCK QARRY)*

## SHELTERS

### *IGLOO*

1. Mark a circle in the snow 6' in diameter. Using hard snow, cut blocks 1' wide, 1.5' high and 2' long. Place the blocks in a circle, then trim to form a spiral ramp.
2. As the next ring of blocks is laid, tilt each block inward slightly to narrow the circle. Continue spiraling upward creating the dome, which prevents the walls from caving in. **Note:** As you lay blocks, leave the tops uneven until you have laid a full spiral. Then take your snow saw and trim the tops by pointing the saw to an imaginary point in the center of the igloo floor.

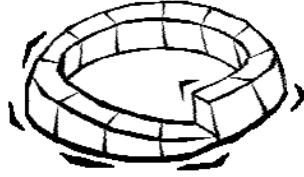

3. When your walls are 3' to 4' high, cut an entry hole to slide blocks inside. The final "keystone" block is wedge or cone shaped. Push the block up from inside, tipping it on its side and then fitting it down.

## SHELTERS

### *IGLOOS*

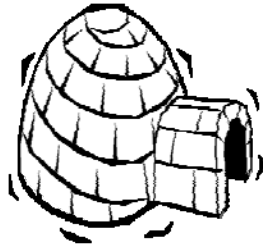

4. Now make a low arched entranceway to crawl inside. Make the entrance about 1' lower than the igloo floor to create a cold trap. Finally, make a small vent hole in the roof and door if you are closing the entranceway.



## SHELTERS

### *SNOW TRENCH*

The trench igloo can be built either on a slope or on the flat. It is a quick emergency shelter for one or two people. Dig a narrow trench and roof the trench, A-frame style, with snow blocks. The blocks can be created as part of the process of removing snow from the trench, or they can be quarried near-by. Then enlarge the interior and provide a vent hole. Smooth out any irregularities in the ceiling so that condensation will run down the blocks and not drip on the occupants. This shelter is not as easy to build as it looks, so practice first in good weather.

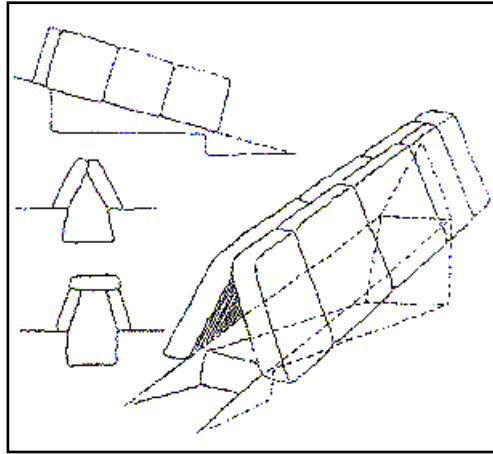

## **SHELTERS**

### *SNOW TRENCH*

A more basic emergency snow-shelter can be built by digging a trench some four to six feet deep. Make it large enough for the entire party. Stretch a tarp over the top, perhaps gaining a slight angle by anchoring one side to a ridge of snow. This works well in wind or rain, but a heavy snowfall can lapse a roof that is nearly flat. The smaller the trench the easier it is to keep warm. Again, be sure to provide for ventilation.

## MAP AND COMPASS

### *TAKING A BEARING FROM THE MAP*

*(MAP NOT ORIENTED):*

1. Lay the long edge of the compass base plate on the map, making a line from the starting point to the destination (from point X to point Y). Since the base plate is parallel to the direction of travel arrow, the base plate can be used to set the direction to the destination.
2. Holding the base plate steady, rotate the compass housing until the compass orienting lines and orienting arrow are pointing to true north. Here you see the orienting lines and arrow are parallel to the line from A to B as well as to the map gridlines.
3. Read the bearing (in degrees) from the degree dial at the point on the compass base plate marked "Read bearing here."

## MAP AND COMPASS

### *TAKING A BEARING FROM THE LAND*

1. Point the compass.
2. Rotate the compass housing until the north-orienting arrow of the compass housing lines up with the red magnetic needle. This is referred to as "boxing the needle," since you want the needle to be inside the box defined by the orienting arrow. The north-orienting arrow must be pointing in the same direction as the red (north) magnetic needle.
3. Read the bearing (in degrees) from the degree dial at the point on the compass base plate.
4. After taking the bearing, as described above, hold the compass level and in front of you, so that the direction of travel arrow points to the destination.

## **MAP AND COMPASS**

### *WALKING A BEARING TAKEN FROM THE LAND:*

5. Rotate your whole body until the magnetic needle lies directly over the orienting arrow. Make sure the north end of the magnetic needle points to N on the compass housing. The direction of travel arrow points to the destination.
6. Site a prominent feature to which your direction of travel arrow points. Walk to that feature. Continue to sight on other features along the bearing and walk to them, until you reach your destination.

## MAP AND COMPASS

### *BACK BEARINGS*

To check your position while walking a bearing, you can take a back bearing. Before you start to walk on your bearing, turn around and take a bearing 180 degrees off the bearing you are going to walk. For example, if you are going to walk a bearing of 45 degrees, shoot a bearing directly opposite your course of 225 degrees. Locate some landmark along this bearing. Once you have moved a short distance along your bearing, turn around and shoot a bearing back to that landmark. If you are on course, that bearing will still read 180 degrees off your bearing of travel. If it does not, it means that you are off course.

## MAP AND COMPASS

### *WALKING AROUND OBSTACLES*

*When you reach an obstacle, the best method for maintaining your course is to hike a rectangle around the object.*

1. Set a new bearing 90 degrees from your original heading and walk that until you have cleared the obstacle along that axis. For example, if your original bearing was 30 degrees, hike a new bearing of 120 degrees. While walking, maintain a count of paces or otherwise track the distance traveled.
2. Go back onto your original bearing, parallel to your original course until you clear the obstacle along that axis.
3. Set a bearing 90 degrees back to your original bearing (in this case 300 degrees) and walk the same number of paces.
4. Now turn back to your original bearing. You will be along your original line of travel.

## MAP AND COMPASS

### *TRIANGULATION*

Triangulation is used to locate your position when two or more prominent landmarks are visible. Even if you are not sure where you are, you can find your approximate position as long as you can identify at least two prominent landmarks (mountain, end of a lake, bridge, etc.) both on the land and on your map.

1. Orient the map.
2. Look around and locate prominent landmarks.
3. Find the landmarks on the map (preferably at least 90 degrees apart).
4. Determine the bearing of one of the landmarks (*see bearings page 80*).
5. Place the compass on the map so that one side of the base plate points toward the landmark.
6. Keeping the edge of the base plate on the symbol, turn the entire compass on the map until the orienting arrow and the compass needle point to north on the map.

## MAP AND COMPASS

### *TRIANGULATION (continued)*

7. Draw a line on the map along the edge of the base plate, intersecting the prominent landmark symbol. Your position is somewhere along this line.
8. Repeat this procedure for the other prominent landmark. The second landmark should be as close to 90 degrees from the first as possible. Your approximate position is where the two lines intersect.
9. You can repeat this process a third time to show an area bounded by three lines. You are located within this triangle.
10. If you are located on a prominent feature marked on the map such as a ridge, stream, or road, only one calculation from a prominent landmark should be necessary. Your position will be approximately, where the drawn line intersects this linear feature.

## KNOTS

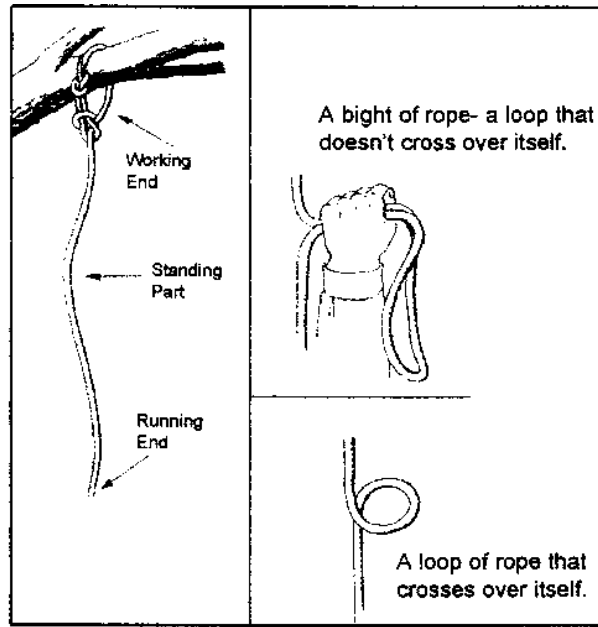

***Relative strengths of knots for single kernmantle rope.***

|              | %     |                   | %     |
|--------------|-------|-------------------|-------|
| Without knot | 100   | Double fishermans | 65-70 |
| Bowline      | 70-75 | Water knot        | 60-70 |
| Figure 8     | 75-80 | Clove hitch       | 60-65 |
| Fisherman's  | 60-65 | Overhand          | 60-65 |

## KNOTS

### *FIGURE-OF-EIGHT LOOP*

The Figure-of-Eight knot is probably the most useful of all climbing knots. It is easy to tie, easy to undo after a load has been applied, and puts the least stress on the rope when tied tight. It can be tied anywhere in the rope, but if it is near the end, it should be secured with a stopper knot to prevent the knot from un-doing itself.

There are generally two methods used to tie a figure of eight knot. The first method is used when a piece of equipment is clipped into the loop, the second when the knot is used to tie into something, for example, a climbing harness.

*Figure-Of-Eight Loop*

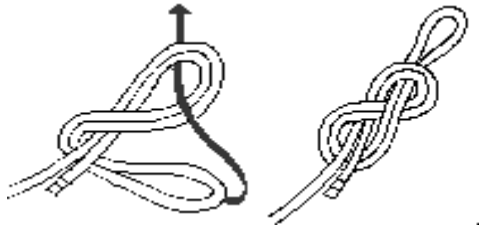

## KNOTS

### *FIGURE-OF-EIGHT RE-THREADED*

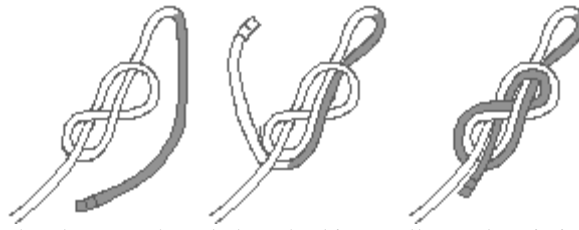

The above re-threaded method is usually used to tie into a harness or rescue sled, and is just a case of making a figure-of-eight on the single rope, looping through the harness, and following the knot back through itself.

### ***Bowline:***



The bowline is easy to adjust and untie. Beware, though, that if tied incorrectly in can be unsafe. You should really tie a stopper knot in the loop with the loose end to prevent it from pulling through.

## KNOTS

### *CLOVE HITCH*

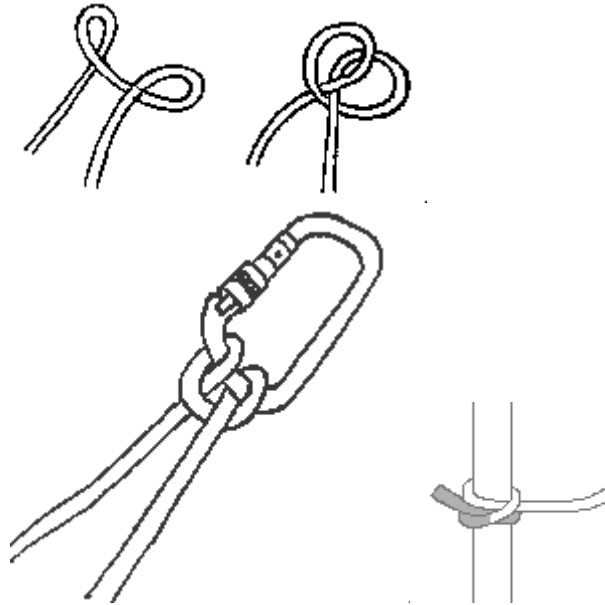

The clove hitch is easily adjusted when in place, but is not a particularly strong knot. If one side of the knot is to be loaded, place the diagonal underneath. If both sides are to be loaded, place the diagonal at the top. Tighten before loading, as it may run if loaded when loose.

## KNOTS

### *DOUBLE FISHERMAN'S KNOT*

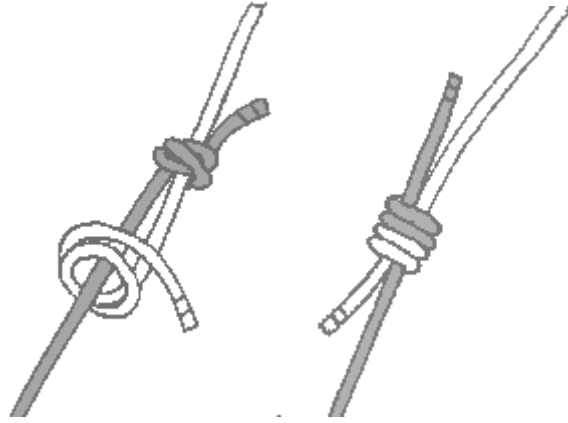

Better than the Fisherman's Knot, this uses two double overhand knots. Good knot, but it can be difficult to untie. Check regularly for the loose ends getting shorter, and if so, re-tie. Tighten with body weight.

## KNOTS

### *WATER KNOT*

The Water knot is used to tie lengths of webbing together or a single length into a loop. Pull hard to set the knot leaving at least 4 - 6 inches of tail. Always add Safety Knots before using.

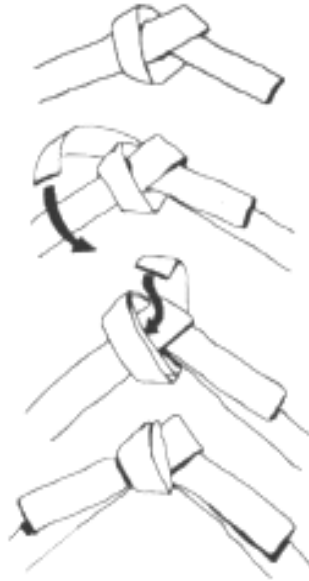

## KNOTS

### *FRICION KNOTS*

#### **The Prusik Knot:**

The good old prusik knot is very, very useful. All you need is a loop of cord, which you can make using 6 or 7mm accessory cord and a double fisherman's knot. With one or two prusiks, you can ascend a rope, or rig a z-pulley to haul up an injured climber, or backup an abseil. Suffice it to say it is worth learning this gem of a knot. There are numerous variations on the prusik such as the "autoblock", but follow these steps to tie the standard prusik knot:

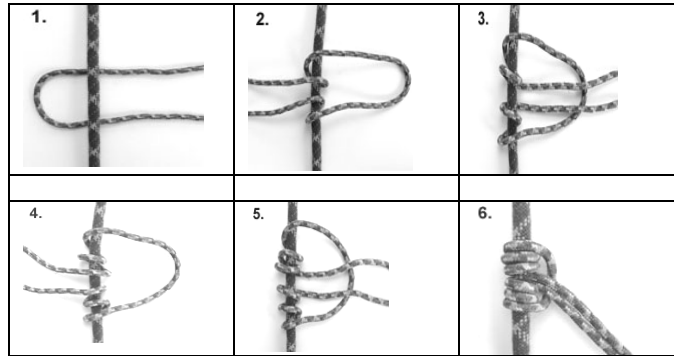

## KNOTS

### PRUSIK

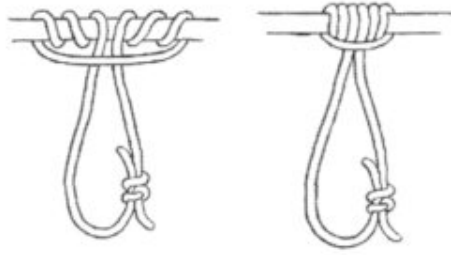

While this is technically a hitch, most rescuers call it a Prusik Knot or just Prusik. The Prusik Hitch

is used to tie one rope onto another in such a manner that the hitch holds when loaded, but will slide easily when loose.

As demonstrated in the diagram, we will use a minimum of three wraps at all times when we use the Prusik.

The ideal situation when using the Prusik is a combination of rope type, rope size differential and number of wraps so that the Prusik Hitch will hold the load you intend to put on it. "Failure" will be the hitch slipping rather than the Prusik rope breaking or cutting the main rope. Other conditions that can affect the reliability of the Prusik Hitch are water, ice, or snow.

## KNOTS

### *SAFETY KNOTS*

#### ***Over Hand Knot:***

Safety knots will be used on all knots tied. The best choice is half a Double Fisherman's Knot and the second is an Overhand Knot. Do not use a Half Hitch for a Safety Knot because it can loosen and come untied. The Safety Knot should be snug up against the main knot to prevent movement.



#### **The Munter Hitch:**



The Munter Hitch is a friction Knot. This means it can be used in place of a belay plate but be warned under heavy loads this knot can wear on your rope fast.

## SNOW ANCHOR

### *SNOW OR ICE BOLLARD*

A bollard is a mound of snow that serves as an anchor when rope or webbing is positioned around it. Snow bollards provide highly reliable anchors for belaying or rappelling in soft snow and are possibly the most reliable in all snow conditions. There is a significant trade-off here, however. It takes a long time to build one.

1. Create a mound by making a trench around an oval area of snow.
2. The bollard should end up as an oval-shaped island of snow. The softer the snow, the broader and deeper the bollard must be: up to 10' wide & 1 1/2 ft deep.
3. Place rope or webbing around the bollard, for more security, pad the back of the bollard with clothing, packs or pickets.

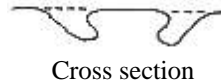
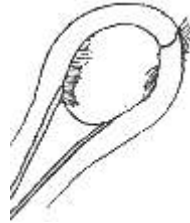

## SNOW ANCHOR

### *T-ANCHOR*

This is an anchor you can use in snow. Simply dig a T-shaped hole attach a piece of cord to your ice-axe and put in your ice-axe; you can use about anything to make this anchor from your backpack to even a piece of wood.

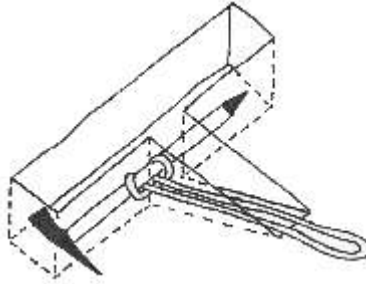

## SNOW ANCHOR

### *SNOW PICKET*

A picket is a stake driven into the snow as an anchor. Aluminum pickets are available in lengths from 18 to 36 inches and are found in different styles, including round or oval tubes and angled or T-section stakes. Pickets work well in snow too firm for flukes but too soft for ice screws. As with flukes, angle them back about 45 degrees from the direction of pull. Attach a carabineer or runner to the picket at the snow line not higher on the picket, or a pull may lever it out. You can drive a picket into the snow with a rock or the side of an ice axe, but a North Wall hammer or other ice hammer works best.

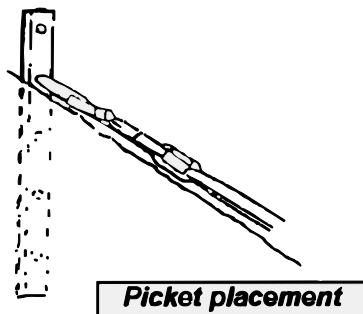

## SNOW ANCHOR

### *TWO- POINT ANCHORS*

**Two-point equalizing**, using two anchors, is the simplest method of self-equalization. Put a half twist in the webbing, which divides the runner into two parts, and clip each end into an anchor with a carabiner. Then clip a locking carabiner over the X formed in the middle, from one half of the runner to the other, and tie into that carabiner.

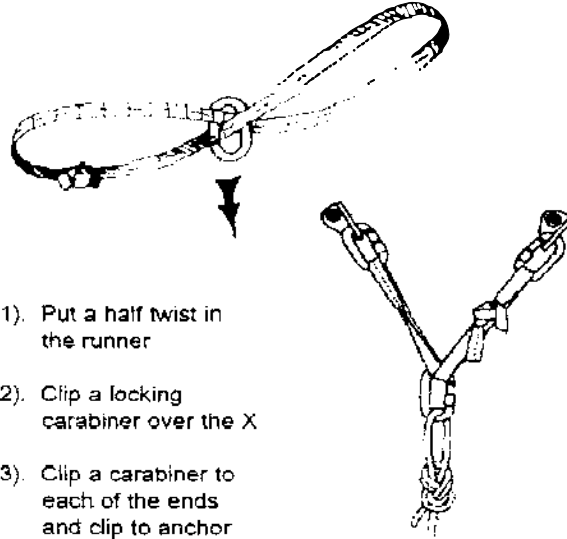

- 1). Put a half twist in the runner
- 2). Clip a locking carabiner over the X
- 3). Clip a carabiner to each of the ends and clip to anchor

**EQUALIZING ANCHOR**

*EQUALIZED TO DIRECTION OF PULL*

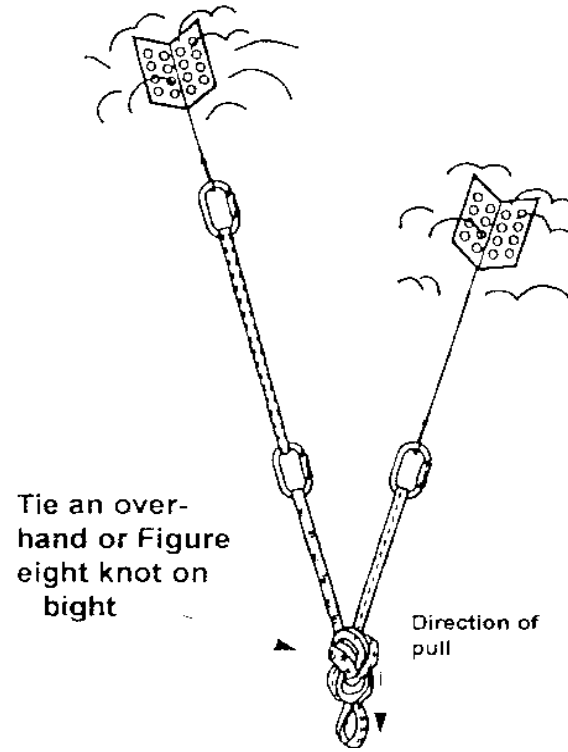

## EQUALIZING ANCHOR

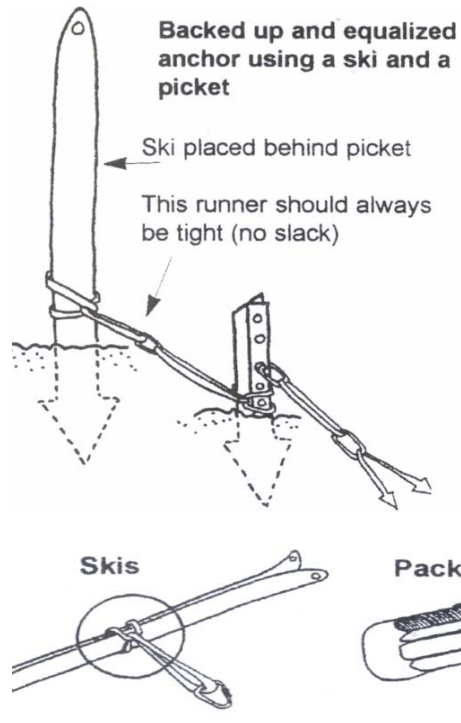

Skis, packs, and snowboards can also be buried and equalized for strong anchors.

## EQUALIZING ANCHOR

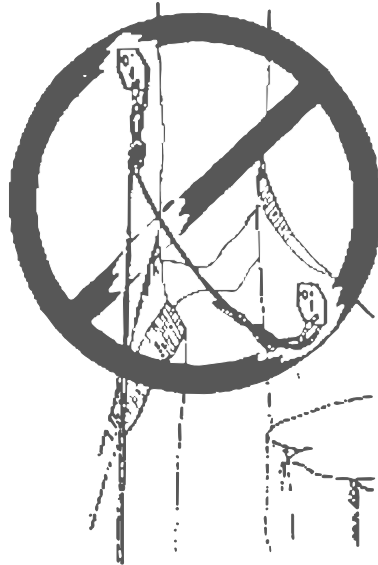

**Load**

**Always think**: What would happen to the rescuers on the other end of the rope if the primary rig point were to fail. In this case, the backup anchor would be severely shock loaded and most likely fail.

## ROBE SYSTEMS

### *EQUALIZING ANCHOR*

#### **Multipoint Construction:**

Multi-point anchors are those, which connect two or more pieces of protection together. This provides redundancy should one piece be weaker than the other(s); if part of the anchor fails there are one or more backups. If the anchor is constructed correctly, loads are distributed between its parts and the force applied to any one piece will be only a part of the total force applied to the system.



## ROBE SYSTEMS

This example of a multipoint equalizing system is set up and works the same as the system on the previous page. The only difference is, instead of putting a half twist in the runner between the carabiners you replace the twists with a carabiner and then add a third carabiner to the main loop. The third carabiner takes the place of the twists by catching the load if two of the 3 anchors.

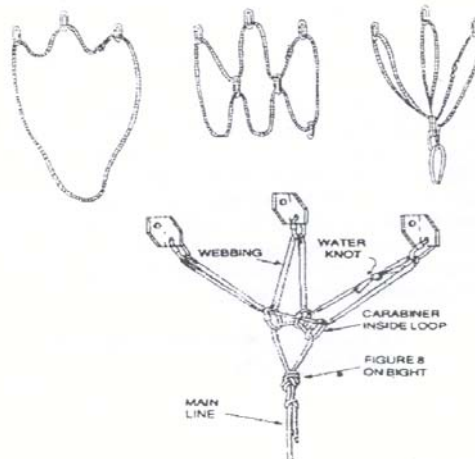

**ROBE SYSTEMS**

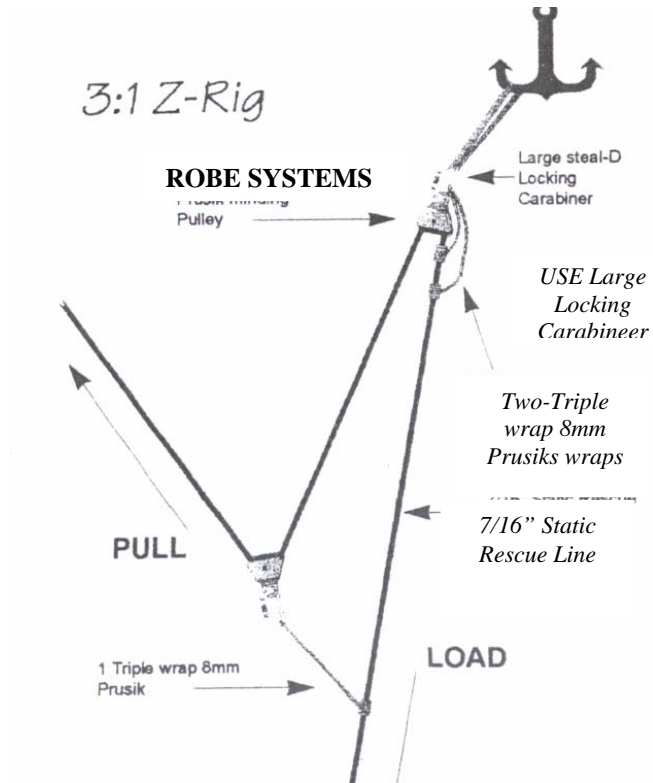

*This system can be used with the backup belay system described on page 108*

## ROPE SYSTEMS

This lowering system uses the brake bar as the lowering device. This system is a reliable and safe method of lowering rescue loads when used with the backup belay system described on **page 108**.

1. Set up a strong reliable anchor.
2. Attach a steal-D carabineer to the anchor.
3. Attach a brake bar to the steal carabineer.  
(Ensure that the brake bar is pulling along the spine of the carabineer).
4. Place the lowering rope into the brake bar and secure ALL of the bars across the rope.  
*NOTE: Do not pass rope between lowest bar and end of rack.*
5. The belayer should be anchored in and always wearing gloves.
6. If there is the possibility of passing a knot through the brake bar a UMIT should be clipped to the anchor and ready to inject into the system.
7. Lower slowly and communicate with backup.

# ROPE SYSTEMS

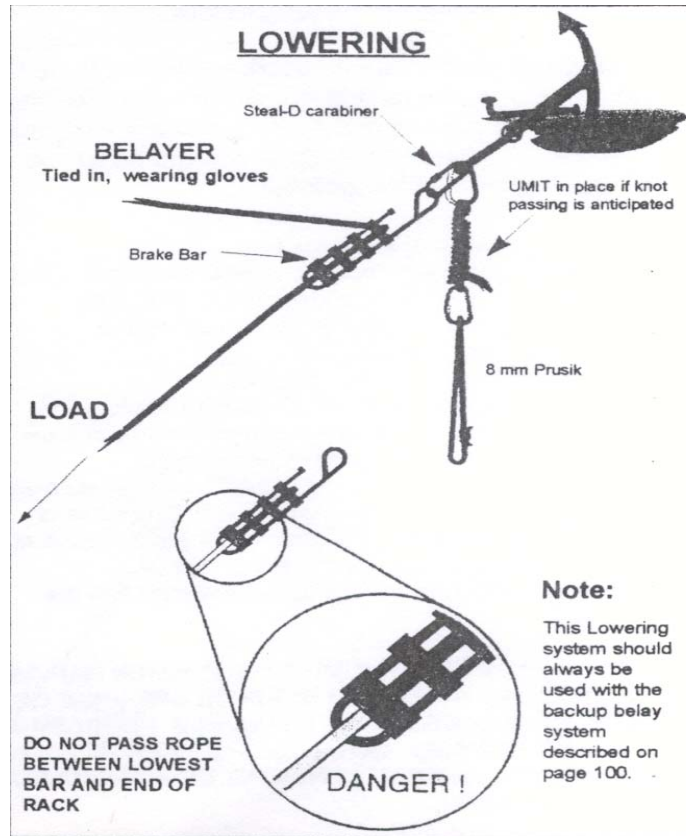

## **BACKUP BELAY SYSTEM**

The backup belay system described here is to be used with both, the raising system and the lowering system. This system is designed to absorb the energy and to hold the load in the event that either the raising or lowering system fails.

1. Set up a strong reliable anchor.
2. Attach a UMIT (with the munter end uphill).
3. Attach a pulley to the opposite end of the UMIT. (Ensure that the pulley is placed along the spine of the carabineer).
4. Place the rescue line into the pulley.
5. Attach 2 triple wrap 8mm prusiks to rescue line. Proper length of prusiks are important to ensure maximum grip if the other system fails. (Prusik lengths: 1 @ 50" and 1 @ 62" (before tied in 1D loop).
6. Assign one person to be the belayer. This job is to ensure that there is the proper tension on the rope at all times and to tend the prusiks.
7. Assign one person to feed or pull the rope thru the pulley.

NOTE: it is extremely important when raising or lowering that both systems are free of slack to reduce shock loading if problems are encountered. Both belayers from each system should be in constant communication with each other.

**ROPE SYSTEMS**

**DOUBLE PRUSIK BELAY (BACKUP)**

*Used in conjunction with Rising and Lowering systems*

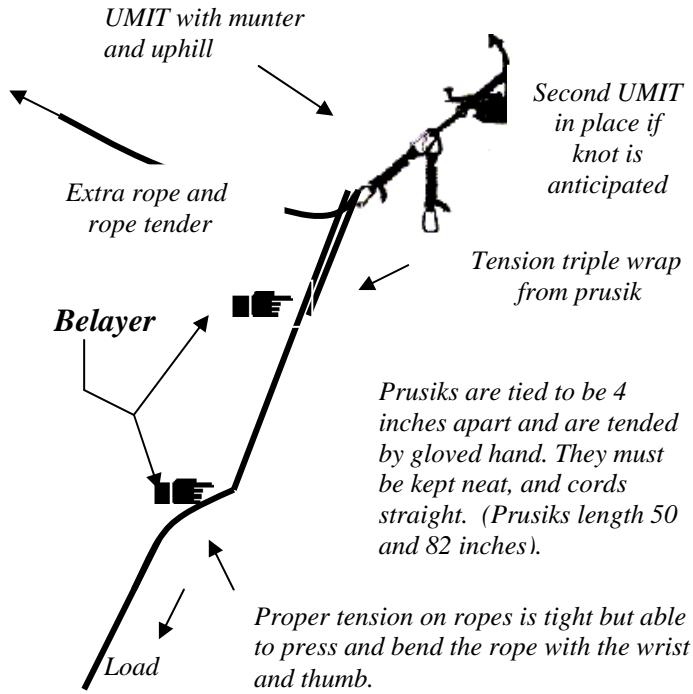

## ROPE SYSTEMS

These two drawings demonstrate how to tie in two ropes to a litter that is being raised up or down a snow slope head first.

1. The first rope should be wrapped in and out around the front end of the litter frame, use about eight wraps.
2. Tie the end of rope back into main line with a Bowline knot. (*Back up the Bowline*).

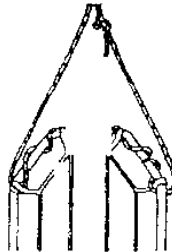

The second rope should be clipped into an equalized runner.

*Litter tie in (1st Rope)*

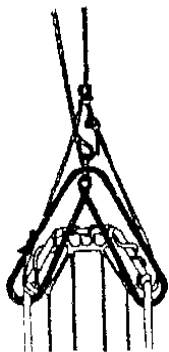

1. Loop 1 long runner through the frame on each side of the litter; then tie ends together with a water knot.
2. Equalize the runner by putting a half twist in the runner and bring it up to the front strand; clip the rope into the loop and strand with a locking carabineer.
3. Tie fig-8 on end of rope and clip into carabineer. (Backup fig-8).

*Litter tie in (2nd Rope)*

## HELICOPTER SAFETY

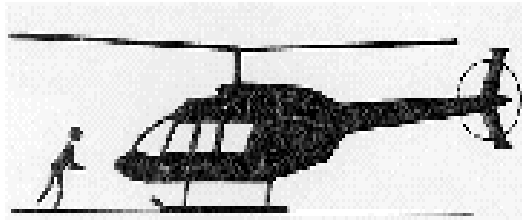

### *APPROACHING THE HELICOPTER*

Approach and depart the helicopter in a crouched position from the front or side of the helicopter within view of the pilot. Never walk to the rear of the helicopter unless loading the rear cabin or baggage compartment, and only if the pilot is aware of your actions.

**Under no circumstances move  
aft (behind) of the baggage compartment.**

**HELICOPTER SAFETY**

***HELICOPTER LANDING AREA***

First, determine the size of the landing area. At a minimum, the touchdown zone should be as follows: During daylight hours- 100' \* 100' square; At night- 125' \* 125' square. The surface should be flat and firm, and free from debris that might blow up into the rotor system.

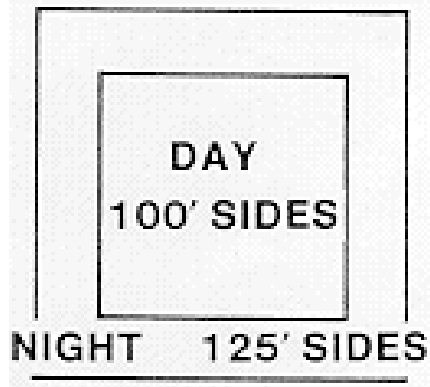

## HELICOPTER SAFETY

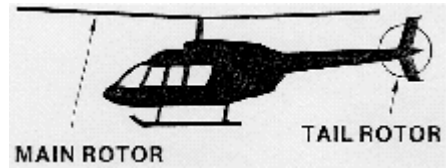

### *ROTOR BLADES*

The helicopter has two sets of rotor blades: The main rotor, the large one on top; and the tail rotor, or the smaller one at the rear of the tail.

The greatest threat when operating around a helicopter is the turning rotor blade. When the blades are turning, the high speed tail rotor is virtually invisible! Physical contact with either of the blades when they are turning could result in serious or fatal injury. On uneven ground, always approach and depart the helicopter from the DOWNHILL side.

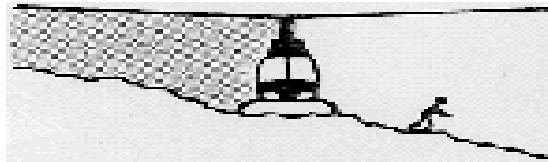

## HELICOPTER SAFETY

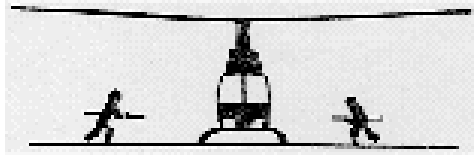

Approach the helicopter with long tool, rods, etc., carried horizontally to avoid possible contact with the main rotor blade.

### ***DANGER AREAS TO AVOID***

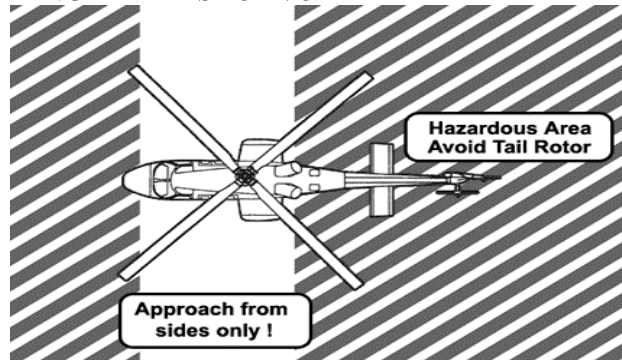

**Always avoid the shaded areas as illustrated**

## HELICOPTER SAFETY

### *IMPORTANT TIPS*

- Approach angles over obstacles should be less than 20 degrees.
- Always keep landing zone clear of people and other potential hazards.
- Approach from 3 and 9 O' Clock positions only (side of helicopter).
- Approach angles over obstacles should be less than 20 degrees.
- Always keep landing zone clear of people and other potential hazards.
- Approach from 3 and 9 O' Clock positions only (side of helicopter).

## HELICOPTER SAFETY



### *GOOD SAFETY PRACTICES*

Always keep your safety belt fastened when in the helicopter. Keep it fastened until the pilot signals that it is safe to unfasten it.

Never smoke in or near a helicopter on the ground. Your pilot will advise you if it is OK to smoke in flight. Smoking on EMS helicopters with an oxygen supply on board is never permitted.

## HELICOPTER SAFETY

### *THE LANDING SITE*

The landing site should be clear of people, obstructions such as trees, pole and wires. Keep in mind that wires are very difficult to see from the air, especially at night. The landing site must be free of stumps, brush, posts and large rocks.

### WHEN THE HELICOPTER IS OVERHEAD

Aircraft will establish radio contact on the assigned frequency with Landing Zone Command five to ten minutes out.

*Describe the following;*

Landing Zone location, Lighting, Hazards, Overhead Wires, Obstructions, Slope, Surface Condition Wind Direction and speed.

**Maintain radio contact at all times until helicopter has landed, loaded, and departed the area.**

## HELICOPTER SAFETY

### *NIGHT OPERATIONS*

- **DO NOT SHINE LIGHTS DIRECTLY AT THE HELICOPTER**
- Do not use cones, flares, or tape to mark the site.
- Emergency vehicles may be parked so their headlights intersect the middle of the landing site and/or parked underneath wires to mark them.
- Lights may be shown onto poles indicating wires between the poles.

